

A CONTROL-ORIENTED BUILDING ENVELOPE AND HVAC SYSTEM SIMULATION MODEL FOR A TYPICAL LARGE OFFICE BUILDING

Sen Huang, Yan Chen, Paul Ehrlich and Draguna Vrabie
Pacific Northwest National Laboratory, Richland, WA

ABSTRACT

In this paper, we present a dynamic simulation model for a typical large office building in the U.S., which can be used as a virtual testbed to enable advanced control research for heating, ventilation, and air conditioning (HVAC) systems. We employed EnergyPlus for calculating the building thermal load, and the Modelica Buildings library to model the dynamic behavior of the HVAC system. We used a functional mockup interface to enable run-time communication between the EnergyPlus model and the Modelica model. This simulation model can be driven by control inputs from the supervisory decision-making algorithms for advanced control system design and performance evaluation. To demonstrate the usage of the model, we performed the evaluation on two representative control sequences for large office buildings with this model. Simulation data allows us to compare the energy performance of these two sequences and captures the evolution of the system dynamics at a high temporal granularity.

INTRODUCTION

In the U. S., buildings consume 41% of the primary energy and 74% of the electricity production (Energy Information Administration 2017). Building energy consumption not only leads to high operational costs, but also has substantial environmental impacts (Omer 2009). In addition, over the past decade, buildings have been recognized as potentially valuable resources for realizing a reliable and robust power grid (U.S. Department of Energy 2016). According to (Dodrill 2011), one-fourth of the U.S. building-related electricity demand in 2010 could be tuned to balance the supply and demand in power systems. Advanced control methods can enhance the energy efficiency of building operations. The aggregated annual energy savings from implementing state-of-the-art control advances alone have been estimated at 29% for a variety of building types (Fernandez et al. 2017). Energy consumption reduction in the range of 24% to 35% could be achieved by applying advanced control techniques to packaged heating, ventilation, and air-conditioning (HVAC) equipment (Wang, Huang, and Katipamula 2012).

Consequently, advanced controls have been proposed. For example, (Huang, Zuo, and Sohn 2016; Huang et al. 2018;

Ma et al. 2008) developed methods to improve the energy efficient operation of chilled water systems. Data center HVAC efficiency optimization is described in (Ham, Park, and Jeong 2015). A review of control-systems-based solutions towards energy savings is given in (Dounis and Caraiscos 2009) and a more recent review looks exclusively at model predictive control in the building context (Afram and Janabi-Sharifi 2014).

Advanced control methods have also been explored for efficient building-to-grid integration, such as frequency regulation, demand response, peak load reduction, and other ancillary services. (Hao et al. 2014) adjusted the power consumption of commercial building supply fans to offer frequency regulation service. (Zhang et al. 2013) developed a control method that can effectually manage a large number of air-conditioning systems to provide various demand response services, such as frequency regulation and peak load reduction. Simulations show that the proposed control methods do not adversely impact occupant thermal comfort.

With the influx of innovative ideas in advanced control methods for building energy efficiency and building-to-grid integration, a standard, effective, and application-oriented testing platform is required for control evaluation and verification before deployment in real systems. Typical approaches for control evaluation include simulation (Pang et al. 2016), hardware-in-loop simulation (Pang et al. 2012), and field tests (Wang et al. 2015).

Simulation is a low-cost approach for comprehensive evaluation of the expected performance of the deployment of a control strategy in the energy domain. Fifty-four whole-building energy simulation tools are summarized in (International Building Performance Simulation Association-USA). Most of these tools have limitations in evaluating control system performance, as they have been designed primarily to assess the long-term building performance. To reduce computational complexity and simulation time, they do not capture the short-term equipment dynamics (Wetter 2011). For example, EnergyPlus (Crawley et al. 2001), while providing outstanding capability in evaluating the expected annual energy performance of building systems, assumes that the local controls, such as the zone temperature control, are ideal: i.e., the controlled variables can be set at desired set points

without any dynamic transition. Under this simplifying assumption, the short-term (a few hours to a week) effects of set-point reset strategies cannot be captured for practical evaluation of control algorithms. Other building simulation tools that are designed to represent short-term system dynamics still make simplifying assumptions on some parts of the system. For example, TRNSYS (Beckman et al. 1994) does not account for pressure drop in the duct network. Thus, it is difficult to evaluate any pressure-based controls, such as the supply fan control, with TRNSYS.

In recognition of these limitations, more and more researchers chose to use general-purpose modeling tools, such as MATLAB/Simulink (MATLAB 2010) and Modelica (Fritzson and Engelson 1998), to develop dynamic models to aid control system development testing. For example, (Chen and Treado 2014) developed a Simulink library of dynamic models for typical air-side HVAC components: (Braun et al. 2012) developed models for building envelope, indoor environment, and the HVAC plants with MATLAB. (Wetter et al. 2014) created a Modelica library that contains the modules for building and district energy heating and control systems.

In this paper, we introduce a virtual testbed for evaluating different control strategies for the HVAC systems that serve typical large office buildings. We used EnergyPlus for calculating the building thermal load and Modelica HVAC Building library (Wetter et al. 2014) to model the dynamic behavior of the HVAC system. A functional mockup interface (Nouidui, Wetter, and Zuo 2014) is used to enable run-time communication between the EnergyPlus model and the Modelica model. To demonstrate the use of the model, we performed the evaluation on two representative sequences of large office buildings, both based on the ASHRAE standards.

This paper contributes to the literature in several ways:

- 1) The first generic virtual testbed is created for large office buildings to evaluate different control strategies in HVAC systems.
- 2) A new co-simulation approach for the efficient and flexible handling of the interactions between buildings and the HVAC systems is proposed.
- 3) An evaluation of the two control sequences based on ASHRAE standards is conducted to illustrate the use of the virtual testbed.

This paper is organized as follows. First, the studied building and the associated HVAC system under study are presented. Then, the implementation of the virtual testbed is discussed, and the control sequences used for a performance comparison are explained. After that, the utilization of the virtual testbed to evaluate the energy performance of two control strategies is demonstrated, followed by conclusions and ideas for future work.

LARGE OFFICE BUILDING SYSTEM

A high-rise large office building was selected for establishing the virtual test-bed. It has twelve identical floors with five zones on each floor. The layout is representative of the large commercial office building stock and is consistent with the building prototypes described in (Deru et al. 2011).

HVAC System

The HVAC system that serves the large office building consists of three major components:

- *One chilled water system*, composed of a chiller, a cooling tower, a primary chilled water loop with a constant speed pump, a secondary chilled water loop with a variable speed pump, and a condenser water loop with a constant speed pump.
- *One hot water system*, consisting of a gas boiler and a constant speed pump.
- *Twelve variable air volume (VAV) systems* (one for each floor). Each VAV system contains an air handling unit (AHU) with two fans and five terminal boxes.

The physical structure of this HVAC system for one floor with the five VAV boxes is illustrated in Figure 1 and an example air distribution loop for one floor is shown in Figure 2.

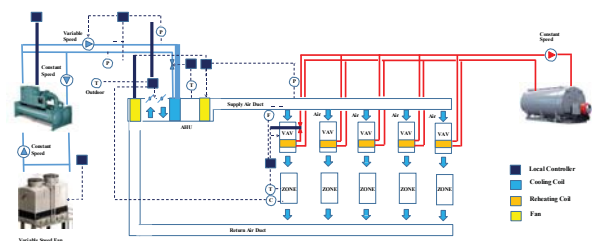

Figure 1 Simplified schematic of the HVAC system with one VAV system

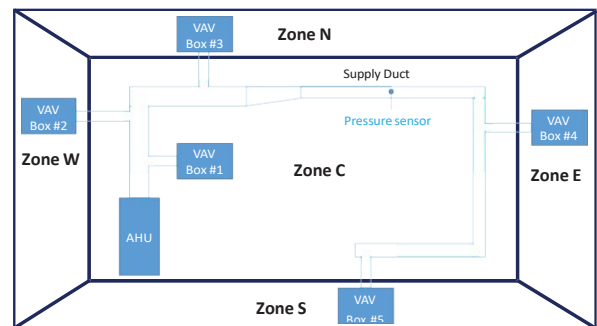

Figure 2 The air distribution loop for one typical floor

Model Integration

To reduce the computation time associated with solving the underlying model without affecting the model's ability to capture the dynamic response of the building equipment, we make two assumptions:

- **Assumption 1:** The thermal load of the building and the weather data are constant within a sample time (e.g., 1 minute);
- **Assumption 2:** The middle floors (from the second floor to the eleventh floor) are identical regarding the operating condition and the sizing of the VAV system.

Co-simulation

With the above assumptions, we developed a hybrid approach to model the system, illustrated in Figure 3, by co-simulating the EnergyPlus envelope model and the Modelica HVAC system model. We based the model of the building envelope and the internal heat gain on the DOE reference building model for Chicago (Deru et al. 2011). The HVAC system models and the control system are developed using the Modelica standard library (Modelica Association 2008) and the Modelica Buildings library (Wetter et al. 2014). The data exchange between the two models is realized with a generic Functional Mockup Interface (FMI) (Blochwitz et al. 2011). Detailed information on the FMI setup in EnergyPlus can be found in (Nouidui, Wetter, and Zuo 2014).

Data exchange between the two models and their associated solvers addresses the coupling between the cooling load and the HVAC system operation (Crawley et al. 2001). (Nouidui, Wetter, and Zuo 2014) proposed a data exchange approach that decouples the relationship by assuming that the temperature, the humidity, and the flow rate of the discharge air are constant during one co-simulation interval. This approach does not capture the fast dynamic evolution of these variables and may lead to inaccuracy in control evaluation. For this reason, we designed the following new data exchange approach.

The EnergyPlus model calculates the building thermal load so that the zone temperatures can be equal to the ones received from the Modelica simulation at the previous data exchange. The EnergyPlus model then communicates the calculated thermal loads to the Modelica model which are set to be constant during the simulation period. Modelica uses the load information to calculate the zone temperatures and send the results back to EnergyPlus. Figure 3 illustrates the data exchange process.

The following equations describe the above process for a given sample time interval $t \in [t_o, t_o + \delta)$, where δ denotes the sample interval.

i) In EnergyPlus, the thermal loads for the building zones

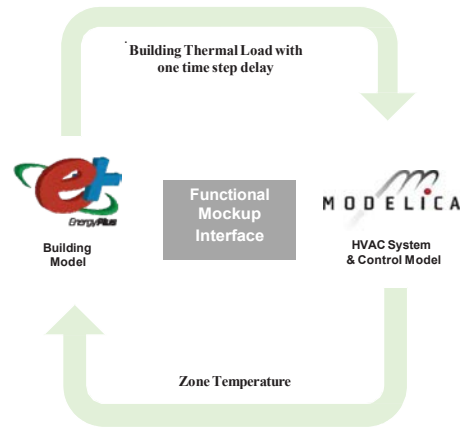

Figure 3 The co-simulated system model

at time t_o , denoted by $Q_e(t_o)$, are calculated by

$$Q_e(t_o) = f(T_s(t_o), I_e(t_o), S_e(t_o)), \quad (1a)$$

$$T_s(t_o) = T_m(t_o), \quad (1b)$$

where $T_s(t_o)$ denotes the vector of desired zone temperatures at time t_o ; $T_m(t_o)$ denotes the vector of zone temperatures computed by Modelica at time t_o ; $I_e(t_o)$ denotes the vector of inputs for the EnergyPlus simulation at time t_o ; $S_e(t_o)$ is the vector of initial states at time t_o .

ii) In Modelica, the vector of zone temperatures at time $t \in [t_o, t_o + \delta)$ is calculated by

$$T_m(t) = g(Q_e(t_o), I_m(t), S_m(t_o)), \quad (2)$$

where $I_m(t)$ is the input vector for the Modelica simulation at time t ; $S_m(t_o)$ is the vector of state variables at time t_o . Note that equations (1) and (2) approximate the solution of the following equations, which describe the interaction between the building thermal load and the HVAC system.

$$Q_e(t) = f(T_s(t), I_e(t), S_e(t_o)), \quad (3a)$$

$$T_m(t) = g(Q_e(t), I_m(t), S_m(t_o)), \quad (3b)$$

$$T_s(t) = T_m(t). \quad (3c)$$

The approximation is accurate when Assumption 1 is valid. Compared to the approach in (Nouidui, Wetter, and Zuo 2014), the solution approach proposed here allows us to represent the dynamics of the HVAC system that may be faster than the co-simulation interval (selected at 1 minute in our case).

Models

Modelica allows us to develop building models hierarchically. Figure 4 shows the building and HVAC system

model including the submodels for the chilled water system, the hot water system, the AHU, the air distribution system, and the functional mockup unit for the EnergyPlus envelope model.

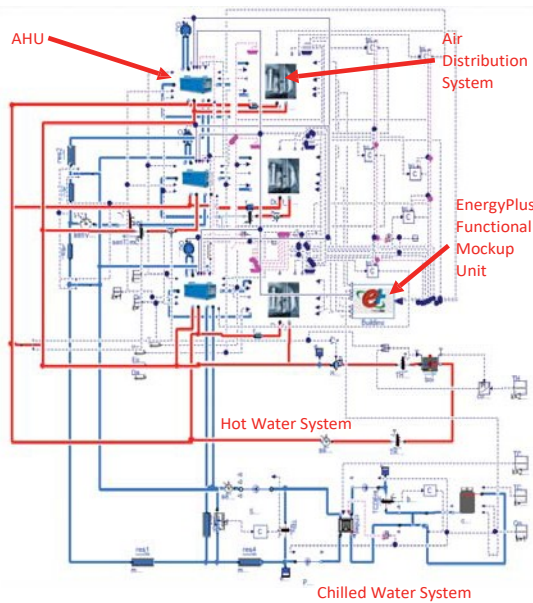

Figure 4 Building and HVAC system model

Figure 5 presents details on the AHU model. The AHU model contains the submodel for the two fans, the cooling coil, and the mixing box. The local controllers for the above components are also implemented.

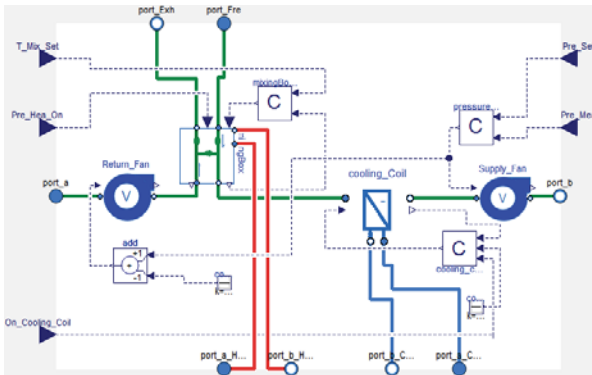

Figure 5 The AHU model

The AHUs and the air distribution systems serving the middle floors are represented by one AHU and one distribution system model, respectively, based on Assumption 2. We create a load-multiplier model, as shown in Figure 6, to ensure that the thermal load for twelve floors is represented in the chilled water and the hot water systems. The

load-multiplier model represents the water flux which has the same return temperature as that for the AHU model representing the middle floor but with n times water flow rate (n denotes the number of middle floors).

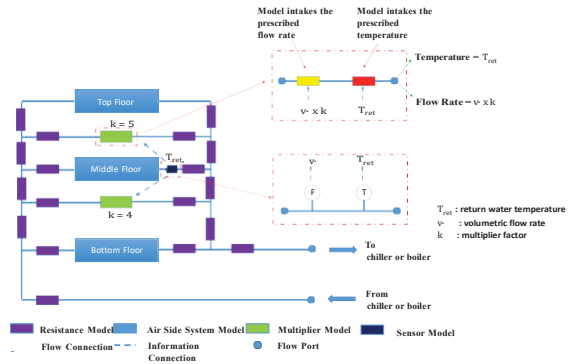

Figure 6 The load-multiplier model

CONTROL SEQUENCES

To demonstrate the usage of the building system model as a virtual testbed, we performed the evaluation on two control sequences (named “Baseline” and “Advanced”) for the air-side system with the model. The two sequences are described in Table 1. “Baseline” represents the case in which advanced reset strategies are not considered, and all the system operating set points are constant. The “Advanced” strategy, based on the first public review draft of the Guideline 36 specification (ASHRAE 2016), represents state of the art in advanced reset sequences to adjust the system set points based on the operating conditions.

As an example, Figure 7 elaborates the discharge air temperature set point reset for the cooling coil control. The discharge air temperature set point is determined based on the number of requests from the building zones which are indicators for the cooling load. Requests are calculated based on the damper position and the deviation of the zone temperatures from the corresponding desired temperature set points. When the number of requests is higher than a specified threshold, the system is demanding more cooling energy, and the discharge air temperature set point is reduced by a fixed amount. Otherwise, the discharge air temperature set point is increased periodically by a fixed amount. This reset strategy may cause the temperature of some zones to surpass the set point when the reset threshold is greater than zero.

It is worth mentioning that it may be difficult to use conventional building tools to evaluate the two control sequences, especially the “Advanced” strategy. The most significant difficulty, as mentioned in the Introduction section, is the inability to catch the fast dynamics. For example, the discharge air temperature set point reset employs

Table 1 Control Sequences (see details for * in (ASHRAE 2016))

Baseline	Advanced
Start system 2 hr ahead of occupancy schedule	Same
Duct static pressure set point is 174.2 Pa	Static pressure resets between 24.9 Pa. and 248.8 Pa based on terminal box status*
Differential speed ratio between the supply and return fan is 10%	Same
Supply air temperature set point is 12.8°C	Supply air temperature set point resets between 12.8°C and 18.3°C*
Minimum outdoor air damper position at 30%	Demand Control Ventilation (ASHRAE 2013)
Fixed dry bulb temperature [15.6°C] control for the air side economizer (Aktacir 2012)	Fixed enthalpy [65kJ/kg] control for the air side economizer (Aktacir 2012)
Single maximum for terminal control (Paliaga 2012)	Dual maximum for terminal control (Paliaga 2012)

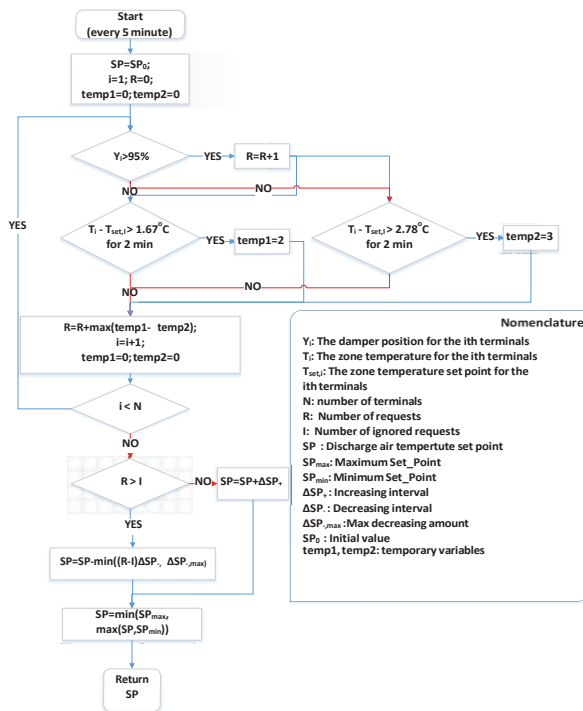

Figure 7 The reset strategy for discharge air temperature set point

a control delay to determine the request based on the temperature deviation to avoid unsteady controls. Therefore, it is critical to consider the delays when implementing the control in the system modeling to faithfully capture the reset performance. However, the delays are difficult, or even impossible, to implement in tools such as Energy-Plus. Therefore, it is our view that the proposed testbed is necessary for control evaluations.

RESULTS & DISCUSSION

Simulation Settings

A simulation of the system was conducted with the two control sequences. Table 1 and Figure 7 give details on the configuration of the reset strategies as recommended by Guideline 36 specifications. For example, ΔSP , ΔSP_{-max} , ΔSP_{+} , and I are set as 0.1, 0.16, 0.5, and 2, respectively. The weather inputs for the simulation are from the TMY3 file (Wilcox and Marion 2008) for O’Hare International Airport, Chicago. To reflect on how the two sequences work at different times of the year, we select three weeks: a week each from August (the summer week), March (the mild week), and January (the winter week). Figure 8 shows the trends in the minutely outdoor temperatures for the three weeks.

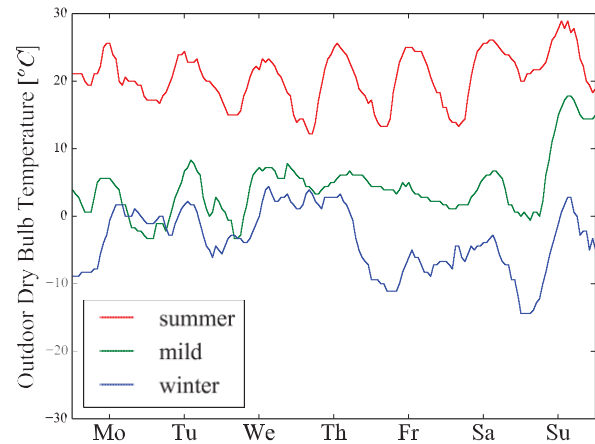

Figure 8 Outdoor air temperature

Results

Figure 9 gives a summary of the electricity consumption for different devices under two control sequences. Based on the results, we can see:

- 1) In general, the “Advanced” control can lead to significant electricity savings for all the three testing weeks, with savings for the week in March being around 35%.
- 2) Compared to the other devices, the savings from the fan electricity consumption are the most significant. For the mild week in March, the savings ratio for the fan electricity consumption with the “Advanced” control is around 71%, compared to the “Baseline” control. For the same week, the “Advanced” control almost eliminates the chiller electricity usage; while in the summer week, the savings ratio is around 16%. On the other hand, the pump electricity consumption seems to be less sensitive to different control sequences as most pumps operate with constant speeds.

3) The electricity consumption savings from the “Advanced” control sequence are comparatively more significant for the mild and winter weeks than the summer week. This is because fan electricity consumption can be reduced to a great extent while the total electricity consumption is lower, compared to the summer week.

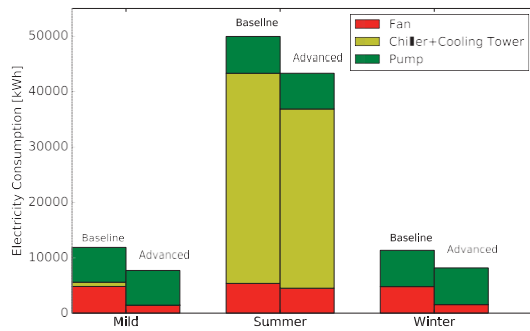

Figure 9 Total electricity consumption for the testing weeks

Likewise, we plotted the result for the gas consumption in Figure 10. We can see that, in general, the gas consumption savings obtained from the “Advanced” control sequence are less than that from the electricity consumption, with a savings ratio of up to 10% approximately.

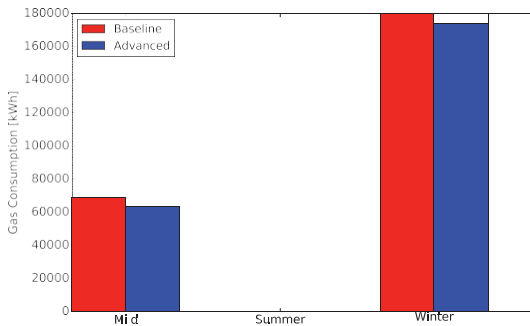

Figure 10 Total gas consumption for the testing weeks

To help understand how the energy savings from the fan and chiller are achieved, we provide more detailed information regarding the duct static pressure set point and the discharge air temperature set point for the middle floor AHU under the two control sequences, as shown in Figure 11. One can see that the duct static pressure set point under the “Advanced” control is always less than that under the “Baseline” control, significantly reducing the fan electricity consumption. On the other hand, since the dis-

charge air temperature set point under the “Advanced” control is always larger than that under the “Baseline” control, the chiller works more efficiently under the former.

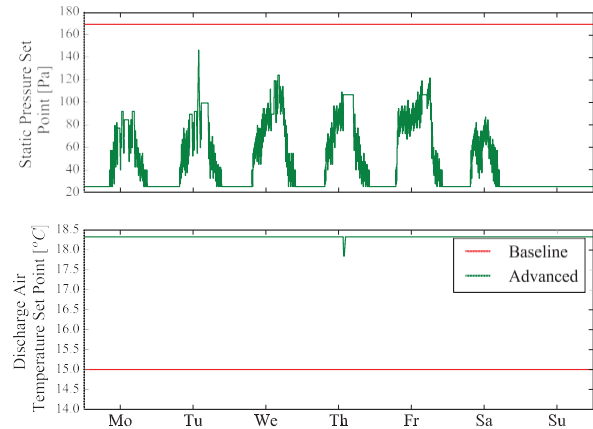

Figure 11 The set points for the duct static pressure and the discharge air temperature for the middle floor AHU

Also, to demonstrate how the two sequences affect thermal comfort, here we also use the middle floor as an example and plot the zone temperature in Figure 12. We found that both the “Baseline” control and the “Advanced” control can maintain the zone temperature within or close to the set range. Moreover, although the physical systems are the same, the zone temperature patterns are different under different control sequences: The zone temperatures are higher under the “Advanced” control than those under the “Baseline” control. Also, the change in zone temperature is smoother under the latter than the former. This observation confirms that the “Advanced” control may sacrifice thermal comfort with the current settings.

CONCLUSION

Based on the above analysis, we can draw the following conclusions:

- 1) The proposed virtual testbed can be used to perform a comprehensive evaluation of the relevant controls, regarding energy savings and the impacts on the thermal comfort.
- 2) In general, the “Advanced” control can significantly reduce the electricity usage by the fans and the chillers, due to the resetting of the duct static pressure set point and the discharge air temperature set point.
- 3) The “Advanced” control may pose small negative impacts on the thermal comfort.

In the future, we would like to use the testbed to understand the optimal settings of the control for a trade-off

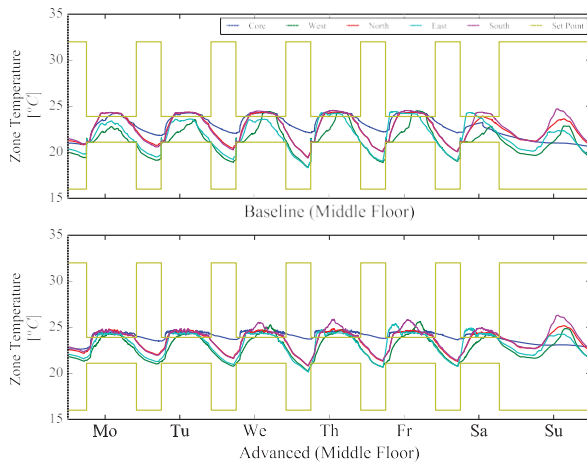

Figure 12 The set points for the duct static pressure and the discharge air temperature for the middle floor AHU

between thermal comfort and energy efficiency. We will also use the virtual testbed for examining advanced control strategies with a particular focus on building-to-grid (B2G) integration. Compared to the controls we evaluated in this paper, the ones used for the B2G integration may require higher fidelity building response. In addition, we also plan to add more building systems, like the domestic hot water system, to the simulation scope for further controls evaluation. Lastly, validations will also be performed to assess the overall accuracy of the testbed and other conventional simulation tools in estimating the building energy performance.

ACKNOWLEDGMENT

This work has been supported by the the Buildings Technologies Office of the U.S. Department of Energys Office of Energy Efficiency and Renewable Energy.

The authors would like to thank Arnab Bhattacharya and Nikitha Radhakrishnan for providing the technical review, Matthew Wilburn for editorial support.

REFERENCES

- Afram, Abdul, and Farrokh Janabi-Sharifi. 2014. "Theory and Applications of HVAC Control Systems A Review of Model Predictive Control (MPC)." *Building and Environment* 72:343 – 355.
- Aktacir, Mehmet Azmi. 2012. "Performance Evaluation of Different Air-side Economizer Control Methods for Energy Efficient Building." *ISI BILIMI VE TEKNIGI DERGISI-Journal of Thermal Science and Technology* 32:19–30.
- ASHRAE. 2013. "62.1.(2016)." *Ventilation for Accept-*

able Indoor Air Quality. American Society of Heating, Refrigerating and Air-Conditioning Engineers.

- ASHRAE. 2016. ASHRAE Guideline 36P, High Performance Sequences of Operation for HVAC systems, First Public Review Draft.
- Beckman, William A., Lars Broman, Alex Fiksel, Sanford A. Klein, Eva Lindberg, Mattias Schuler, and Jeff Thornton. 1994. "TRNSYS, The Most Complete Solar Energy System Modeling and Simulation Software." *Renewable Energy* 5 (1-4): 486–488.
- Blochwitz, Torsten, Martin Otter, Martin Arnold, Constanze Bausch, H. Elmqvist, A Junghanns, J Mauß, M Monteiro, T Neidhold, D Neumerkel, et al. 2011. "The Functional Mockup Interface for Tool Independent Exchange of Simulation Models." *Proceedings of the 8th International Modelica Conference; March 20th-22nd; Technical Univeristy; Dresden; Germany.* Linköping University Electronic Press, 105–114.
- Braun, J, Donghun Kim, Miroslav Baric, Pengfei Li, Satish Narayanan, Shui Yuan, Eugene Cliff, J Burns, and Bill Henshaw. 2012. "Whole Building Control System Design and Evaluation: Simulation-based Assessment." *GPIC Energy Efficient Buildings Hub, Technical Report.*
- Chen, Yan, and Stephen Treado. 2014. "Development of a Simulation Platform based on Dynamic Models for HVAC Control Analysis." *Energy and Buildings* 68:376–386.
- Crawley, Drury B., Linda K. Lawrie, Frederick C. Winkelmann, W.F. Buhl, Y. Joe Huang, Curtis O. Pedersen, Richard K. Strand, Richard J. Liesen, Daniel E. Fisher, Michael J. Witte, and Jason Glazer. 2001. "EnergyPlus: Creating a New-generation Building Energy Simulation Program." *Energy and Buildings* 33 (4): 319–331. Special Issue: BUILDING SIMULATION'99.
- Deru, Michael, Kristin Field, Daniel Studer, Kyle Benne, Brent Griffith, Paul Torcellini, Bing Liu, Mark Halverson, Dave Winiarski, Michael Rosenberg, et al. 2011. "US Department of Energy Commercial Reference Building Models of the National Building Stock."
- Dodrill, Keith. 2011. "Demand Dispatch Intelligent Demand for a More Efficient Grid." Technical Report, Pacific Northwest National Laboratory, Richland, WA.
- Dounis, Anastasios I., and Christos Caraiacos. 2009. "Advanced Control Systems Engineering for Energy and Comfort Management in a Building Environ-

- mentA Review.” *Renewable and Sustainable Energy Reviews* 13 (6-7): 1246–1261.
- Energy Information Administration. 2017. Annual Energy Outlook 2015.
- Fernandez, N., Y. Xie, S. Katipamula, M. Zhao, W. Wang, and C. Corbin. 2017. “Impacts of Commercial Building Controls on Energy Savings and Peak Load Reduction.” Technical Report, Pacific Northwest National Laboratory.
- Fritzon, Peter, and Vadim Engelson. 1998. “ModelicaA Unified Object-oriented Language for System Modeling and Simulation.” *European Conference on Object-Oriented Programming*. Springer, 67–90.
- Ham, Sang-Woo, Jun-Seok Park, and Jae-Weon Jeong. 2015. “Optimum Supply Air Temperature Ranges of Various Air-side Economizers in a Modular Data Center.” *Applied Thermal Engineering* 77:163–179.
- Hao, H., Y. Lin, A. S. Kowli, P. Barooah, and S. Meyn. 2014. “Ancillary Service to the Grid Through Control of Fans in Commercial Building HVAC Systems.” *IEEE Transactions on Smart Grid* 5 (4): 2066–2074 (July).
- Huang, Sen, Ana Carolina Laurini Malara, Wangda Zuo, and Michael D. Sohn. 2018. “A Bayesian Network model for the Optimization of a Chiller Plants Condenser Water Set Point.” *Journal of Building Performance Simulation* 11 (1): 36–47.
- Huang, Sen, Wangda Zuo, and Michael D. Sohn. 2016. “Amelioration of the Cooling Load based Chiller Sequencing Control.” *Applied Energy* 168:204–215.
- International Building Performance Simulation Association-USA. Building Energy Software Tools.
- Ma, Zhenjun, Shengwei Wang, Xinhua Xu, and Fu Xiao. 2008. “A Supervisory Control Strategy for Building Cooling Water Systems for Practical and Real Time Applications.” *Energy Conversion and Management* 49 (8): 2324–2336.
- MATLAB. 2010. *version 7.10.0 (R2010a)*. Natick, Massachusetts: The MathWorks Inc.
- Modelica Association. 2008. “Modelica standard library.” Online, URL: <http://www.modelica.org/libraries/Modelica>.
- Nouidui, Thierry, Michael Wetter, and Wangda Zuo. 2014. “Functional Mock-up Unit for Co-simulation Import in EnergyPlus.” *Journal of Building Performance Simulation* 7 (3): 192–202.
- Omer, Abdeen Mustafa. 2009. “Energy Use and Environmental Impacts: A General Review.” *Journal of Renewable and Sustainable Energy* 1, no. 053101.
- Paliaga, Gwelen. 2012. “Dual Maximum VAV Box Control Logic.” *Ashrae Journal* 54 (12): 16.
- Pang, Xiufeng, Thierry S. Nouidui, Michael Wetter, Daniel Fuller, Anna Liao, and Philip Haves. 2016. “Building Energy Simulation in Real Time Through an Open Standard Interface.” *Energy and Buildings* 117:282–289.
- Pang, Xiufeng, Michael Wetter, Prajesh Bhattacharya, and Philip Haves. 2012. “A Framework for Simulation-based Real-time Whole Building Performance Assessment.” *Building and Environment* 54:100–108.
- U.S. Department of Energy. 2016. “The National Opportunity for Interoperability and its Benefits for a Reliable, Robust, and Future Grid Realized Through Buildings.” Technical Report.
- Wang, W., Y. Huang, and S. Katipamula. 2012. “Energy Savings and Economics of Advanced Control Strategies for Packaged Heat Pumps.” Technical Report, Pacific Northwest National Laboratory.
- Wang, Weimin, Srinivas Katipamula, Hung Ngo, Ronald Underhill, Danny Taasevigen, and Robert Lutes. 2015. “Field Evaluation of Advanced Controls for the Retrofit of Packaged Air Conditioners and Heat Pumps.” *Applied Energy* 154:344–351.
- Wetter, Michael. 2011, April. *A View on Future Building System Modeling and Simulation*.
- Wetter, Michael, Wangda Zuo, Thierry S Nouidui, and Xiufeng Pang. 2014. “Modelica Buildings Library.” *Journal of Building Performance Simulation* 7 (4): 253–270.
- Wilcox, Stephen, and William Marion. 2008. “Users Manual for TMY3 Data Sets (Revised).” Technical Report, National Renewable Energy Lab.(NREL), Golden, CO, U.S.
- Zhang, W., J. Lian, C. Y. Chang, and K. Kalsi. 2013. “Aggregated Modeling and Control of Air Conditioning Loads for Demand Response.” *IEEE Transactions on Power Systems* 28 (4): 4655–4664 (Nov).