

Fig. 3 Mortality in Mice Exposed to Aerosolized Influenza

Note that numbers of deaths and lung lesions were minimized when humidity was held between 40 and 60% rh.

[Adapted from Brundrett (1990), *Criteria for Moisture Control*. Copyright Elsevier © 1990.]

equipment, whereas low relative humidity may promote static electricity. Also, rapid changes in relative humidity should be avoided because of their effect on bar code readers, magnetic tapes, disks, and data processing equipment. Generally, computer systems have a recommended design and operating range of 35 to 55% rh. However, the manufacturer's recommendations should be adhered to for specific equipment operation.

Process Control and Materials Storage

The relative humidity required by a process is usually specific and related to one or more of several factors:

- Control of moisture content or regain
- Rate of chemical or biochemical reactions
- Rate of crystallization
- Product accuracy or uniformity
- Corrosion
- Static electricity

Typical conditions of temperature and relative humidity for storage of certain commodities and manufacturing and processing of others may be found in Chapter 14 of the 2015 *ASHRAE Handbook—HVAC Applications*.

Low humidity in winter may cause drying and shrinking of furniture, wood floors, and interior trim. Winter humidification should be considered to maintain relative humidity closer to that experienced during manufacture or installation.

For storing hygroscopic materials, maintaining constant humidity is often as important as the humidity level itself. The design of the structure should always be considered. Temperature control is important because of the danger of condensation on products through a transient lowering of temperature.

Static Electricity

Electrostatic charges are generated when materials of high electrical resistance move against each other. The accumulation of such charges may have a variety of results: (1) unpleasant sparks caused by friction between two materials (e.g., stocking feet and carpet fibers); (2) difficulty in handling sheets of paper, fibers, and fabric; (3) objectionable dust clinging to oppositely charged objects (e.g.,

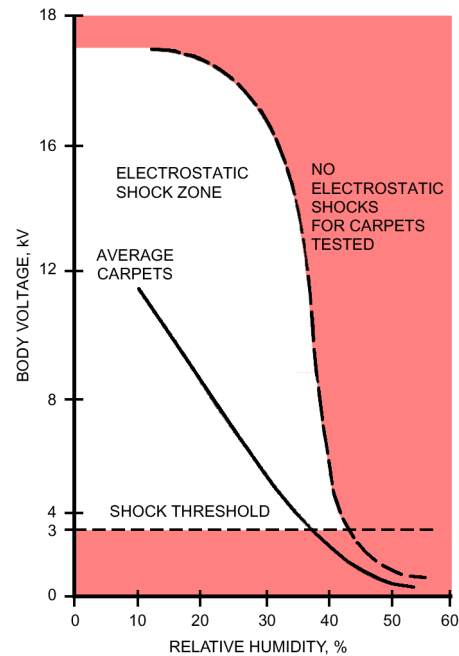

Fig. 4 Effect of Relative Humidity on Static Electricity from Carpets

Below 40% rh, perceptible shocks are more likely. [Adapted from Brundrett (1990), *Criteria for Moisture Control*. Copyright Elsevier © 1990.]

negatively charged metal nails or screws securing gypsum board to wooden studding in the exterior walls of a building that attract positively charged dust particles); (4) destruction of data stored on magnetic disks and tapes that require specifically controlled environments; and (5) hazardous situations if explosive gases are present, as in hospitals, research laboratories, or industrial clean rooms.

Increasing the relative humidity of the environment reduces the accumulation of electrostatic charges, but the optimum level of humidity depends to some extent on the materials involved. Figure 4 illustrates the voltage that can be accumulated in the human body at different humidity levels. Relative humidity of 45% reduces or eliminates electrostatic effects in many materials, but wool and some synthetic materials may require a higher relative humidity.

Hospital operating rooms, where explosive mixtures of anesthetics are used, constitute a special and critical case. A relative humidity of at least 50% is usually required, with special grounding arrangements and restrictions on the types of clothing worn by occupants. Conditions of 72°F and 55% rh are usually recommended for comfort and safety.

Sound Wave Transmission

Air absorption of sound waves, which results in the loss of sound strength, is worst at 15 to 20% rh, and the loss increases as the frequency rises (Harris 1963). There is a marked reduction in sound absorption at 40% rh; above 50%, the effect of air absorption is negligible. Air absorption of sound does not significantly affect speech but may merit consideration in large halls or auditoriums where optimum acoustic conditions are required for musical performances.

Miscellaneous

Laboratories and test chambers, in which precise control of relative humidity over a wide range is desired, require special attention. Because of the interrelation between temperature and relative humidity, precise humidity control requires equally precise temperature control.

2. ENCLOSURE CHARACTERISTICS

Vapor Retarders

The maximum relative humidity level to which a building may be humidified in winter depends on the ability of its walls, roof, and other elements to prevent or tolerate condensation. Condensed moisture or frost on surfaces exposed to the building interior (visible condensation) can deteriorate the surface finish, cause mold growth and subsequent indirect moisture damage and nuisance, and reduce visibility through windows. If the walls and roof have not been specifically designed and properly protected with vapor retarders on the warm side to prevent the entry of moist air or vapor from the indoors, concealed condensation within these constructions is likely to occur, even at fairly low interior humidity, and cause serious deterioration.

Visible Condensation

Condensation forms on an interior surface when its temperature is below the dew-point temperature of the air in contact with it. The maximum relative humidity that may be maintained without condensation is thus influenced by the thermal properties of the enclosure and the interior and exterior environment.

Average surface temperatures may be calculated by the methods outlined in Chapter 25 of the 2013 *ASHRAE Handbook—Fundamentals* for most insulated constructions. However, local cold spots result from high-conductivity paths such as through-the-wall framing, projected floor slabs, and metal window frames that have no thermal breaks. The vertical temperature gradient in the air space and surface convection along windows and sections with a high thermal conductivity result in lower air and surface temperatures at the sill or floor. Drapes and blinds closed over windows lower surface temperature further, while heating units under windows raise the temperature significantly.

In most buildings, windows present the lowest surface temperature and the best guide to permissible humidity levels for no condensation. While calculations based on overall thermal coefficients provide reasonably accurate temperature predictions at mid-height, actual minimum surface temperatures are best determined by test. Wilson and Brown (1964) related the characteristics of windows with a **temperature index**, defined as $(t - t_o)/(t_i - t_o)$, where t is the indoor window surface temperature, t_i is the indoor air temperature, and t_o is the outdoor air temperature.

The results of limited tests on actual windows indicate that the temperature index at the bottom of a double, residential-type window with a full thermal break is between 0.55 and 0.57, with natural convection on the warm side. Sealed, double-glazed units exhibit an index from 0.33 to 0.48 at the junction of glass and sash, depending on sash design. The index is likely to rise to 0.53 or greater only 1 in. above the junction.

With continuous under-window heating, the minimum index for a double window with a full break may be as high as 0.60 to 0.70. Under similar conditions, the index of a window with a poor thermal break may be increased by a similar increment.

Figure 5 shows the relationship between temperature index and the relative humidity and temperature conditions at which condensation occurs. The limiting relative humidities for various outdoor temperatures intersect vertical lines representing particular temperature indexes. A temperature index of 0.55 was selected to represent an average for double-glazed, residential windows; 0.22 represents an average for single-glazed windows. Table 1 shows the limiting relative humidities for both types of windows at various outdoor air temperatures.

Concealed Condensation

Vapor retarders are imperative in certain applications because the humidity level a building is able to maintain without serious

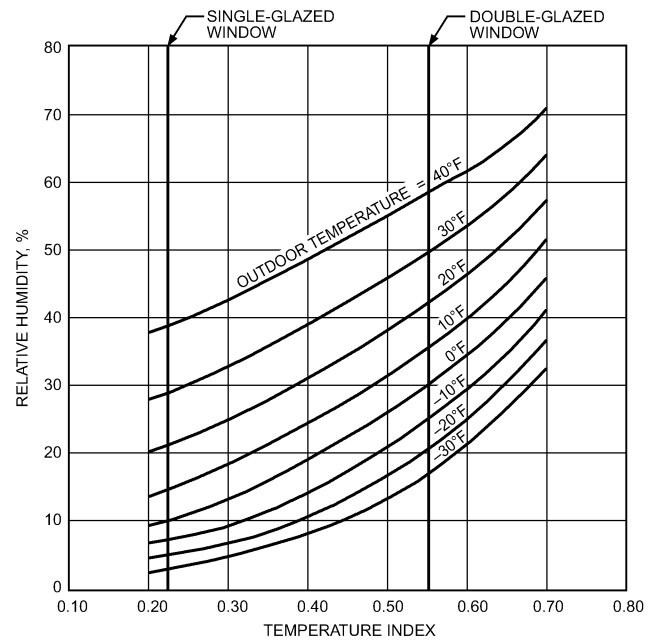

Fig. 5 Limiting Relative Humidity for No Window Condensation

Table 1 Maximum Relative Humidity in a Space for No Condensation on Windows

| Outdoor Temperature, °F | Limiting Relative Humidity, % | |
|-------------------------|-------------------------------|----------------|
| | Single Glazing | Double Glazing |
| 40 | 39 | 59 |
| 30 | 29 | 50 |
| 20 | 21 | 43 |
| 10 | 15 | 36 |
| 0 | 10 | 30 |
| -10 | 7 | 26 |
| -20 | 5 | 21 |
| -30 | 3 | 17 |

Note: Natural convection, indoor air at 74°F.

concealed condensation may be much lower than that indicated by visible condensation. Migration of water vapor through the inner envelope by diffusion or air leakage brings the vapor into contact with surfaces at temperatures below its dew point. During building design, the desired interior humidity may be determined by the building enclosure’s ability to handle internal moisture. This is particularly important when planning for building humidification in colder climates.

3. ENERGY CONSIDERATIONS

When calculating energy requirements for a humidification system, the effect of dry air on any material supplying it with moisture should be considered. The release of liquid in a hygroscopic material to a vapor state is an evaporative process that requires energy. The source of energy is heat contained in the air. Heat lost from the air to evaporate moisture equals the heat necessary to produce an equal amount of moisture vapor with an efficient humidifier. If proper humidity levels are not maintained, moisture migration from hygroscopic materials can have destructive effects.

The true energy required for a humidification system must be calculated from the actual humidity level in the building, not from the theoretical level.

A study of residential heating and cooling systems showed a correlation between infiltration and indoor relative humidity, indicating a significant energy saving from increasing the indoor relative humidity, which reduced infiltration of outdoor air by up to 50% during the heating season (Luck and Nelson 1977). This reduction is apparently due to sealing of window cracks by frost formation.

To assess accurately the total energy required to provide a desired level of humidity, all elements relating to the generation of humidity and the maintenance of the final air condition must be considered. This is particularly true when comparing different humidifiers. For example, the cost of boiler steam should include generation and distribution losses; costs for an evaporative humidifier include electrical energy for motors or compressors, water conditioning, and addition of reheat (when the evaporative cooling effect is not required).

Load Calculations

The humidification load depends primarily on the rate of natural infiltration of the space to be humidified or the amount of outdoor air introduced by mechanical means. Other sources of moisture gain or loss should also be considered. The **humidification load** H can be calculated by the following equations:

For ventilation systems having natural infiltration,

$$H = \rho VR(W_i - W_o) - S + L \quad (1)$$

For mechanical ventilation systems having a fixed quantity of outdoor air,

$$H = 60\rho Q_o(W_i - W_o) - S + L \quad (2)$$

For mechanical systems having a variable quantity of outdoor air,

$$H = 60\rho Q_i(W_i - W_o) \left(\frac{t_i - t_m}{t_i - t_o} \right) - S + L \quad (3)$$

where

- H = humidification load, lb of water/h
- V = volume of space to be humidified, ft³
- R = infiltration rate, air changes per hour
- Q_o = volumetric flow rate of outdoor air, cfm
- Q_i = total volumetric flow rate of air (outdoor air plus return air), cfm
- t_i = design indoor air temperature, °F
- t_m = design mixed air temperature, °F
- t_o = design outdoor air temperature, °F
- W_i = humidity ratio at indoor design conditions, lb of water/lb of dry air
- W_o = humidity ratio at outdoor design conditions, lb of water/lb of dry air
- S = contribution of internal moisture sources, lb of water/h
- L = other moisture losses, lb of water/h
- ρ = density of air at sea level, 0.074 lb/ft³

Design Conditions

Interior design conditions are dictated by the occupancy or the process, as discussed in the preceding sections on Enclosure Characteristics and on Environmental Conditions. Outdoor relative humidity can be assumed to be 70 to 80% at temperatures below 32°F or 50% at temperatures above 32°F for winter conditions in most areas. Additional data on outdoor design data may be obtained from Chapter 14 of the 2013 *ASHRAE Handbook—Fundamentals*. Absolute humidity values can be obtained either from Chapter 1 of the 2013 *ASHRAE Handbook—Fundamentals* or from an ASHRAE psychrometric chart.

For systems handling fixed outdoor air quantities, load calculations are based on outdoor design conditions. Equation (1)

should be used for natural infiltration, and Equation (2) for mechanical ventilation.

For economizers that achieve a fixed mixed air temperature by varying outdoor air, special considerations are needed to determine the maximum humidification load. This load occurs at an outdoor air temperature other than the lowest design temperature because it is a function of the amount of outdoor air introduced and the existing moisture content of the air. Equation (3) should be solved for various outdoor air temperatures to determine the maximum humidification load. It is also important to analyze the energy use of the humidifier (especially for electric humidifiers) when calculating the economizer setting in order to ensure that the energy saved by “free cooling” is greater than the energy consumed by the humidifier.

In residential load calculations, the actual outdoor design conditions of the locale are usually taken as 20°F and 70% rh, while indoor conditions are taken as 70°F and 35% rh. These values yield an absolute humidity difference ($W_i - W_o$) of 0.0040 lb per pound of dry air for use in Equation (1). However, the relative humidity may need to be less than 35% to avoid condensation at low outdoor temperatures (see Table 1).

Ventilation Rate

Ventilation of the humidified space may be caused by natural infiltration alone or natural infiltration in combination with intentional mechanical ventilation. Natural infiltration varies according to the indoor-outdoor temperature difference, wind velocity, and tightness of construction, as discussed in Chapter 16 of the 2013 *ASHRAE Handbook—Fundamentals*. The rate of mechanical ventilation may be determined from building design specifications or estimated from fan performance data (see *ASHRAE Standard* 62.1).

In load calculations, water vapor removed from the air during cooling by air-conditioning or refrigeration equipment must be considered. This moisture may have to be replaced by humidification equipment to maintain the desired relative humidity in some industrial projects where the moisture generated by the process may be greater than that required for ventilation and heating.

Estimates of infiltration rate are made in calculating heating and cooling loads for buildings; these values also apply to humidification load calculations. For residences where such data are not available, it may be assumed that a tight house has an infiltration rate of 0.5 air changes per hour (ach); an average house, 1 ach; and a loose house, as many as 1.5 ach. A tight house is assumed to be well insulated and to have vapor retarders, tight storm doors, windows with weather stripping, and a dampered fireplace. An average house is insulated and has vapor retarders, loose storm doors and windows, and a dampered fireplace. A loose house is generally one constructed before 1930 with little or no insulation, no storm doors, no insulated windows, no weather stripping, no vapor retarders, and often a fireplace without an effective damper. For building construction, refer to local codes and building specifications.

Additional Moisture Losses

Hygroscopic materials, which have a lower moisture content than materials in the humidified space, absorb moisture and place an additional load on the humidification system. An estimate of this load depends on the absorption rate of the particular material selected. Table 2 in Chapter 14 of the 2015 *ASHRAE Handbook—HVAC Applications* lists the equilibrium moisture content of hygroscopic materials at various relative humidities.

In cases where a certain humidity must be maintained regardless of condensation on exterior windows and walls, the dehumidifying effect of these surfaces constitutes a load that may need to be considered, if only on a transient basis. The loss of water vapor by diffusion through enclosing walls to the outdoors or to areas at a lower vapor pressure may also be involved in some applications. The properties of materials and flow equations given in Chapter 26 of the

2013 *ASHRAE Handbook—Fundamentals* can be applied in such cases. Normally, this diffusion constitutes a small load, unless openings exist between the humidified space and adjacent rooms at lower humidities.

Internal Moisture Gains

The introduction of a hygroscopic material can cause moisture gains to the space if the moisture content of the material is above that of the space. Similarly, moisture may diffuse through walls separating the space from areas of higher vapor pressure or move by convection through openings in these walls (Brown et al. 1963).

Moisture contributed by human occupancy depends on the number of occupants and their degree of physical activity. As a guide for residential applications, the average rate of moisture production for a family of four has been taken as 0.7 lb/h. Unvented heating devices produce about 1 lb of vapor for each pound of fuel burned. These values may no longer apply because of changes in equipment as well as in living habits.

Industrial processes constitute additional moisture sources. Single-color offset printing presses, for example, give off 0.45 lb of water per hour. Information on process contributions can best be obtained from the manufacturer of the specific equipment.

Supply Water for Humidifiers

There are three major categories of supply water: potable (untreated) water, softened potable water, and demineralized [deionized (DI) or reverse osmosis (RO)] water. Either the application or the humidifier may require a certain water type; consult the humidifier manufacturer’s literature.

In areas with water having a high mineral content, precipitated solids may be a problem: they can clog nozzles, tubes, evaporative elements, and controls. In addition, solids allowed to enter the airstream via mist leave a fine layer of white dust over furniture, floors, and carpets. Some wetted-media humidifiers bleed off and replace some or all of the water passing through the element to reduce the concentration of salts in the recirculating water.

Dust, scaling, biological organisms, and corrosion are all potential problems associated with water in humidifiers. Stagnant water can provide a fertile breeding ground for algae and bacteria, which have been linked to odor and respiratory ailments. Bacterial slime reacts with sulfates in the water to produce hydrogen sulfide and its characteristic bad odor. Regular maintenance and periodic disinfecting with approved microbicides may be required (Puckorius et al. 1995). This has not been a problem with residential equipment; however, regular maintenance is good practice because bio-cides are generally used only with atomizing humidifiers.

Scaling

Industrial pan humidifiers, when supplied with water that is naturally low in hardness, require little maintenance, provided a surface skimmer bleedoff is used.

Water softening is an effective means of eliminating mineral precipitation in a pan-type humidifier. However, the concentration of sodium left in a pan as a result of water evaporation must be held below the point of precipitation by flushing and diluting the tank with new softened water. The frequency and duration of dilution depend on the water hardness and the rate of evaporation. Dilution is usually accomplished automatically by a timer-operated drain valve and a water makeup valve.

Demineralized or reverse osmosis (RO) water may also be used. The construction materials of the humidifier and the piping must withstand the corrosive effects of this water. Commercial demineralizers or RO equipment removes hardness and other total dissolved solids completely from the humidifier makeup water. They are more expensive than water softeners, but no humidifier purging is required. Sizing is based on the maximum required water flow to the

humidifier and the amount of total dissolved solids in the makeup water.

Potential Bacterial Growth

Certain microorganisms are occasionally present in poorly maintained humidifiers. To deter the propagation and spread of these detrimental microorganisms, periodic cleaning of the humidifier and draining of the reservoir (particularly at the end of the humidification season) are required. Research by Unz et al. (1993) on several types of plenum-mounted (evaporative and steam) residential humidifiers showed no evidence of organism transmission originating from the humidifier. Ruud et al. (1993) also determined that humidifiers (evaporative and steam) did not add bacteria or particles to the heated airstream.

4. EQUIPMENT

Humidifiers can be broken into two basic categories, depending on when the energy is added for converting the water from a liquid to a gas in the humidification process. Each process results in different air temperatures during the humidification process, as seen in Figure 6. Table 2 shows the types of humidifiers in each category. See Chapter 1 of the 2013 *ASHRAE Handbook—Fundamentals* for more information on the humidification process.

Isothermal units use external energy to produce a steam vapor, and the humidification process results in a near-constant air temperature. All of the energy for producing the steam is added by the humidifier unit, before it enters the airstream. Isothermal units are typically called steam units by those in the industry, and fall into a couple of different groups of equipment as detailed in the paragraphs below. Because isothermal units produce only steam vapor, they are considered non-aerosol-generating humidifiers.

Table 2 Types of Humidifiers

| Isothermal | Adiabatic |
|---------------------------|----------------------------|
| Steam heat exchanger | Ultrasonic atomizer |
| Hot-water heat exchanger | Centrifugal atomizer |
| Direct-injection steam | Pressurized-water atomizer |
| Electrode steam | Compressed air atomizer |
| Electric resistance steam | Wetted media |
| Gas-fired steam | Hybrid spray/media |
| Electric infrared steam | |

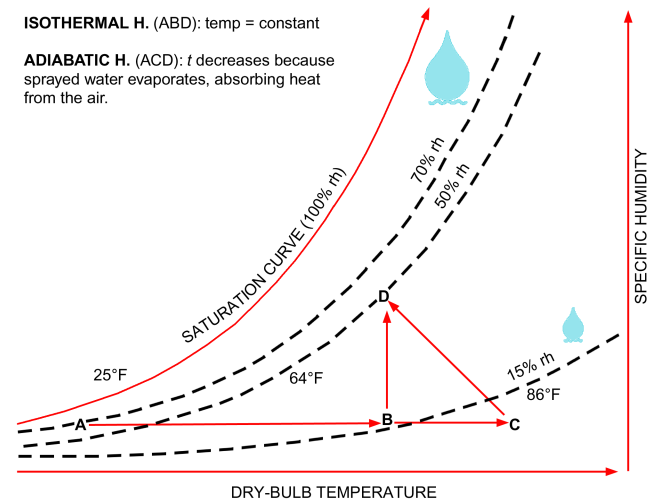

Fig. 6 Adiabatic Versus Isothermal Humidification Process
(Courtesy CAREL)

Adiabatic units allow direct contact between the water and airstream, and the humidification process results in a lower air temperature. All of the energy for the transformation, from liquid to gas, is provided by the airstream. Adiabatic units are typically called atomizers or evaporative systems, and fall into a couple of different groups of equipment: atomizing units are considered aerosol-generating, because they introduce water droplets directly into the airstream, whereas evaporative units are considered non-aerosol-generating, because the process only involves air absorbing the moisture as it passes over a pan or wetted device.

In Figure 6, during humidification, the isothermal system results in the air transformation of B to D. For the adiabatic system, the air transformation is shown as step C to D. For either process, the preheating steps of A to B or A to C are external to the humidification system, and are part of the air-handling system. Step B to C is equal to the energy that is required to convert the water from a liquid to a gas during the adiabatic process.

Humidifiers can generally be classified as either residential or industrial, although residential humidifiers can be used for small industrial applications, and small industrial units can be used in large homes. Equipment designed for use in central air systems also differs from that for space humidification, although some units are adaptable to both.

Air washers and direct evaporative coolers may be used as humidifiers; they are sometimes selected for additional functions such as air cooling or air cleaning, as discussed in Chapter 41.

The capacities of residential humidifiers are generally based on gallons per day of operation; capacities of industrial and commercial humidifiers are based on pounds per hour of operation. Published evaporation rates established by equipment manufacturers through test criteria may be inconsistent. Rates and test methods should be evaluated when selecting equipment. The Air-Conditioning, Heating and Refrigeration Institute (AHRI) developed *Standard 610* for residential central system humidifiers, *Standard 620* for self-contained residential units, and *Standard 640* for commercial and industrial humidifiers. Association of Home Appliance Manufacturers (AHAM) *Standard HU-1* addresses self-contained residential units.

Residential Humidifiers for Central Air Systems

Residential humidifiers designed for central air systems depend on airflow in the heating system for evaporation and distribution. General principles and description of equipment are as follows:

Pan Humidifiers. Capacity varies with temperature, humidity, and airflow. Vapor is introduced into the air by evaporation.

- **Basic pan.** A shallow pan is installed within the furnace plenum. Household water is supplied to the pan through a control device.
- **Electrically heated pan.** Similar to the basic unit, this type adds an electric heater to increase water temperature and evaporation rate.
- **Pan with wicking plates.** Similar to the basic unit, this type includes fitted water-absorbent plates. The increased area of the plates provides greater surface area for evaporation to take place (Figure 7A).

Wetted-Element Humidifiers. Capacity varies with air temperature, water temperature, humidity, and airflow volume. Vapor is introduced into the air by evaporation. Air circulates over or through an open-textured, wetted medium. The evaporating surface may be a fixed pad wetted by either sprays or water flowing by gravity, or a paddle-wheel, drum, or belt rotating through a water reservoir. The various types are differentiated by the way air flows through them:

- **Fan type.** A small fan or blower draws air from the furnace plenum, through the wetted pad, and back to the plenum. A fixed pad (Figure 7B) or a rotating drum-type pad (Figure 7C) may be used.

- **Bypass type.** These units do not have their own fan, but rather are mounted on the supply or return plenum of the furnace with an air connection to the opposite plenum (Figure 7D). The difference in static pressure created by the furnace blower circulates air through the unit.
- **In-duct type.** These units are designed for installation within the furnace plenum or ductwork with a drum element rotated by either the air movement in the duct or a small electric motor.

Atomizing Humidifiers. The capacity of an atomizing humidifier does not depend on the air conditions. However, it is important not to oversaturate the air and allow liquid water to form in the duct. The air's ability to absorb moisture depends on the temperature, flow rate, and moisture content of the air moving through the system. Small particles of water are formed and introduced into the airstream in one of the following ways:

- A **spinning disk or cone** throws a water stream centrifugally to the rim of the disk and onto deflector plates or a comb, where it is turned into a fine fog (Figure 7E).
- Spray nozzles rely on **water pressure** to produce a fine spray.
- Spray nozzles use **compressed air** to create a fine mist.
- **Ultrasonic vibrations** are used as the atomizing force, to produce a fine mist or fog.

Self-Contained Electro Steam Humidifiers (Figure 7G). These units operate by passing an electric current directly into ordinary tap water, thereby creating heat energy to boil the water, and produce steam vapor. The humidifier usually contains a plastic bottle (see Figure 8E) that is supplied with water through a solenoid valve. Periodic and partial drains maintain a desirable solids concentration and the correct electrical flow. Units are available for steam distribution into the duct with a steam nozzle or wand, or into a room with a booster fan.

Residential Humidifiers for Nonducted Applications

Many portable or room humidifiers are used in residences heated by nonducted hydronic or electric systems, or where the occupant is prevented from making a permanent installation. These humidifiers may be equipped with humidity controllers.

Portable units evaporate water by any of the previously described means, such as heated pan, fixed or moving wetted element, or atomizing spinning disk. They may be tabletop-sized or a larger, furniture-style appliance (Figure 7F). A multispeed motor on the fan or blower may be used to adjust output. Portable humidifiers usually require periodic filling from a bucket or filling hose.

Some portable units are offered with an auxiliary package for semipermanent water supply. This package includes a manual shut-off valve, a float valve, copper or other tubing with fittings, and so forth. Lack of drainage provision for water overflow may result in water damage.

Some units may be recessed into the wall between studs, mounted on wall surfaces, or installed below floor level. These units are permanently installed in the structure and use forced-air circulation. They may have an electric element for reheat when desired. Other types for use with hydronic systems involve a simple pan or pan plate, either installed within a hot-water convector or using the steam from a steam radiator.

Industrial and Commercial Humidifiers for Central Air Systems

Humidifiers must be installed where the air can absorb the vapor; the temperature of the air being humidified must exceed the dew point of the space being humidified. When fresh or mixed air is humidified, the air may need to be preheated to allow absorption to take place.

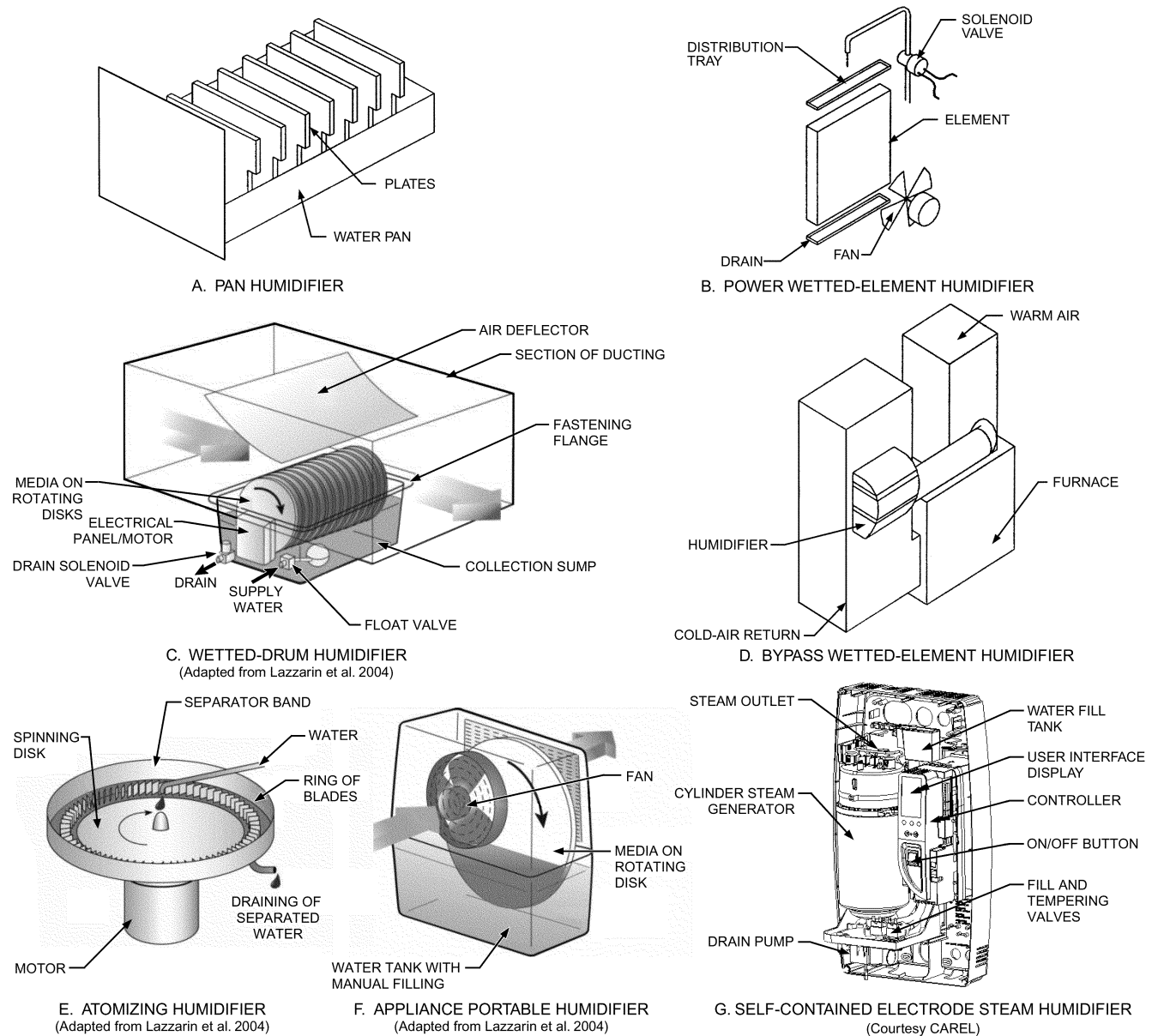

Fig. 7 Residential Humidifiers

Heated Pan Humidifiers. These units offer a broad range of capacities and may be heated by a heat exchanger supplied with either steam or hot water (Figure 8A). They may be installed directly under the duct, or they may be installed remotely and feed vapor through a hose. In either case, a distribution manifold should be used.

Steam heat exchangers are commonly used in heated-pan humidifiers, with steam pressures ranging from 5 to 15 psig. Hot-water heat exchangers are also used in pan humidifiers; a water temperature below 240°F is not practical.

All pan-type humidifiers should have water regulation and some form of drain or flush system. When raw water is used, periodic cleaning is required to remove the buildup of minerals. (Using softened or demineralized water can greatly extend time between cleanings.) Care should also be taken to ensure that all water is drained off when the system is not in use to avoid the possibility of bacterial growth in the stagnant water.

Direct Steam Injection Humidifiers. These units cover a wide range of designs and capacities. Steam is water vapor under pressure and at high temperature, so the process of humidification can be simplified by adding steam directly into the air. This method is an isothermal process because the temperature of the air remains almost constant as the moisture is added. For this type of humidification system, the steam source is usually a central steam boiler at low pressure. When steam is supplied from a source at a constant supply pressure, humidification responds quickly to system demand. A control valve may be modulating or two-position in response to a humidity sensor/controller. Steam can be introduced into the airstream through one of the following devices:

- Single or multiple **steam-jacketed manifolds** (Figure 8B), depending on the size of the duct or plenum. The steam jacket is designed to reevaporate any condensate droplets before they are discharged from the manifold.

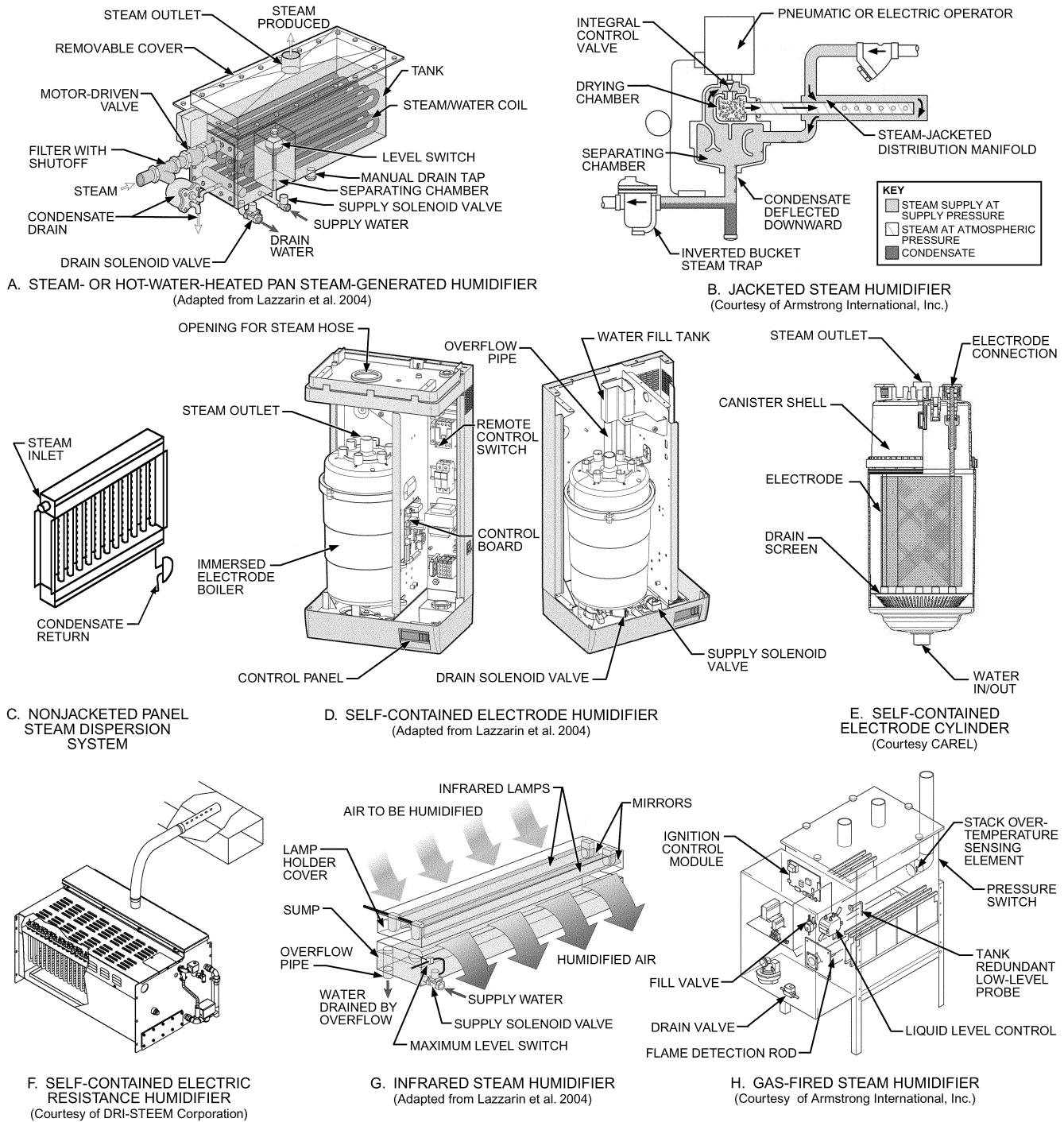

Fig. 8 Industrial Isothermal (Steam) Humidifiers

• **Nonjacketed manifold or panel-type distribution systems** (Figure 8C), with or without injection nozzles for distributing steam across the face of the duct or plenum.

Units must be installed where the air can absorb the discharged vapor before it comes into contact with components in the airstream, such as coils, dampers, or turning vanes. Otherwise, condensation can occur in the duct. Absorption distance varies according to the design of the humidifier distribution device and the air conditions within the duct. For proper psychrometric calculations, refer to Chapter 1 of the 2013 *ASHRAE Handbook—Fundamentals*. Because

these humidifiers inject steam from a central boiler source directly into the space or distribution duct, boiler treatment chemicals discharged into the air system may compromise indoor air quality. Check chemicals for safety, and carefully avoid contamination from the water or steam supplies.

Self-Contained Steam Humidifiers. These units convert ordinary city tap water to steam by electrical or gas energy using either electrodes, resistance heater elements, infrared lamps, or gas combustion. Steam is generated at atmospheric pressure and discharged into the duct system through dispersion manifolds; if the humidifier is

a freestanding unit, the steam is discharged directly into the air space or mixed in the airstream. Some units allow use of softened or demineralized water, which greatly extends the time between cleanings.

- **Electrode humidifiers** (Figure 8D) operate by passing an electric current directly into ordinary tap water, thereby creating heat energy to boil the water and produce steam vapor. The humidifier usually contains a plastic bottle (Figure 8E), either throwaway or cleanable, that is supplied with water through a solenoid valve. Periodic and partial drains maintain a desirable solids concentration and the correct electrical flow. Manufacturers offer humidifiers with several different features, so their data should be consulted.
- **Resistance humidifiers** (Figure 8F) use one or more electrical elements that heat water directly to produce steam. The water can be contained in a stainless or coated steel shell. The element and shell should be accessible for cleaning out mineral deposits. High and low water levels should be controlled with either probes or float devices, and a blowdown drain system should be incorporated, particularly for off-operation periods.
- **Infrared humidifiers** (Figure 8G) use one or more quartz lamps to produce infrared energy that is reflected off mirrors and into a tank of water. The boiling water produces steam, which is then removed by air flowing over the surface of the tank. The water level and dilution drains are controlled by either solenoid valves, or an overflow system.
- **Gas-fired humidifiers** (Figure 8H) use one or more forced air combustion burners and heat exchangers to heat water to produce steam. The water is typically contained in a stainless steel tank, and the heat exchangers can be made from stainless steel or aluminum. The heat exchanger and tank should be accessible for cleaning out mineral deposits. High and low water levels should be controlled with either probes or float devices, and a blowdown drain system should be incorporated, particularly for off-operation periods.

Steam Distributors. Humidifiers that produce steam require a steam distributor to introduce the steam into an airstream or conditioned space. Correct selection and installation of both the steam distributors and the steam lines from the humidifier are essential for proper performance of the humidification system.

There are three common steam distributor types:

- **Individual-tube** distributors consist of one or more perforated tubes that are inserted into a section of ductwork. Steam from the humidifier escapes through holes in the tubes while condensate is collected and drained. Tubes are generally designed to span the width of the duct, and can be used individually or in groups to achieve a certain performance level.
- **Short absorption manifolds** (Figure 8C) are used in ducted or air handler applications and consist of multiple perforated distributor tubes connected to a central header. The multiple tubes spread the steam across as much of the airstream as possible, thus reducing the time and distance needed for the steam to be absorbed. However, the additional distributor tubes result in increased condensate loss and heat transfer to the airstream compared with a single-tube distributor. To minimize this effect, many short absorption manifolds are available with insulation.
- **Room fan** distributors are used for direct room humidification without relying on a central HVAC system. Fan distributors can be built directly onto a humidifier or remotely mounted to distribute steam in a desired location. These distributors have the advantage of allowing the humidifier to operate independently of the ventilation system; however, they can result in a visible steam plume in the room. This plume may require some distance to fully absorb, so fans must be positioned with adequate clearance from occupants, walls, ceilings, and equipment. In addition, fan distributors also generate some noise from the motor and air movement

in the fan. Both sound and absorption clearance are important considerations when placing these devices, particularly in quiet office environments.

Individual-Tube and Short Absorption Manifold Considerations. Both individual-tube and short absorption manifold distributors require tubes placed directly in an airstream. Increasing the number of tubes tends to shorten steam absorption distance, because the steam is more evenly distributed across the cross section of the airstream; however, it also increases the exposed area for heat transfer and thus also increases airstream heat gain and condensate losses in the distributor. It is best practice to minimize the number of tubes used while still maintaining absorption within the available distance. This approach reduces condensate losses and airstream heat gain while also reducing installation cost. To further reduce losses and improve efficiency, many manufacturers offer insulated distributors.

Tubes and short absorption manifolds should both be located in a straight section of ductwork with laminar airflow. Avoid placing these distributors immediately after bends or in areas where turbulent airflow can be expected. Eddies and recirculation currents in these locations can cause the steam to be drawn into duct walls and condense.

Although not strictly required, it is good practice to include a drain pan in the distributor section to protect against possible leaks or condensation from the distributor.

Duct-mounted sensors and controls should be placed far enough away from the distributor for the moisture to mix adequately with the airstream. As a rule of thumb, high-limit controls and humidity sensors should be installed downstream at a minimum distance of five times the expected absorption distance.

Atmospheric Steam Lines. The steam lines that connect the humidifier to the steam distributors are another important part of the humidification system. Steam lines must be correctly sized, properly routed, made of correct material, have adequate drainage, and be insulated.

Sizing. Follow manufacturer guidelines when selecting an overall diameter. Lines that are too narrow create restriction that is difficult for the humidifier to overcome and can reduce system efficiencies. Lines that are too large have very low steam flow velocities and can cause high condensate losses. As a starting point, consider matching the diameter of the steam line to the outlet of the humidifier and maintaining this diameter through to the distributor.

Routing. Most stand-alone isothermal humidifiers generate atmospheric steam [i.e., steam at a very low pressure (0.2 to 0.7 psi)]. As such, steam flow in these lines cannot travel long distances. Consider the following when routing steam lines:

- Keep atmospheric steam lines as short as possible
- Avoid long horizontal runs
- Maintain at a minimum slope of 15% for upward lines
- Maintain a minimum slope of 4% for downward lines
- Ensure lines are adequately supported to avoid unintentional low points
- Minimize the number of elbow and tee fittings

Materials. Material selection is an important aspect of steam line design. Common materials for atmospheric steam lines include copper tubing, stainless steel tubing, and hose. Compared to tubing, **pipng** is costlier to install, has thicker walls, and has higher containment ratings that are not necessary for atmospheric steam. **Steam hose** is typically made of a flexible rubber or polymer material. Restrict steam hoses to short runs of 10 ft or less, because the materials can soften and sag over time. Ensuring adequate support of steam hose is important to avoid low points where condensate can collect and block steam flow.

Plastic tubing and black iron piping are generally not recommended as materials for atmospheric steam lines. Certain types of plastic tubing can emit odors or become brittle from repeated heating cycles. Similarly, black iron pipe can emit odors from oils used during the manufacturing process and is prone to corrosion.

Draining. Condensate forms inside steam lines from heat losses and from cool lines on start-up. To minimize the risks of choking steam flow or discharging condensate from the distributor, this condensate should be removed through drains along the steam lines. It is best practice to place a drain and trap immediately before the distributor to collect and drain condensate before it can enter the distributor. Additionally, drains and traps should be placed every 15 ft on steam line runs, and at any low points in the line. Low points often occur as the steam line is routed under beams, ductwork, or other piping.

A condensate drain should consist of a full-sized tee placed in the steam line, and a pressure trap. At a minimum, the trap must be sized to resist the maximum expected duct static pressure.

Condensate drained from steam lines can be recovered back to the humidifier, returned to a water treatment system, stored for irrigation and toilet usage, or directed to drain as directed by local codes. Steam line condensate is hot, often near 212°F, and should be cooled before draining. Commonly, a high-temperature condensate pump or a condensate cooling tank is used for this purpose.

Insulating. Heat transfer from steam lines can cause steam to condense back to liquid water. Losses in steam lines can reduce the overall system efficiency and reduce the amount of steam being distributed to the space. In the worst cases, significant line losses can prevent the humidifier from maintaining the desired humidity in the space. Therefore, atmospheric steam lines should be insulated with a suitable insulation for the chosen material.

Atomizing Humidifiers. Water treatment should be considered if mineral fallout from hard water is a problem. Optional filters may be required to remove mineral dust from humidified air (Figure 9A). Depending on the application and the water condition, atomizing humidifiers may require a reverse osmosis (RO) or a deionized (DI) water treatment system to remove the minerals. It is also important to note that wetted parts should be able to resist the corrosive effects of DI and RO water. Atomizing humidifiers introduce fine droplets or a fog, directly into the airstream. A mist elimination system is suggested for all atomizing-type humidifiers.

There are four main categories of atomizing humidifiers:

- **Ultrasonic humidifiers** (Figure 9B) use a piezoelectric transducer submerged in demineralized water. The transducer converts a high-frequency mechanical electric signal into a high-frequency oscillation. A momentary vacuum is created during the negative oscillation, causing the water to cavitate into vapor at low pressure. The positive oscillation produces a high-compression wave that drives the water particle from the surface to be quickly absorbed into the airstream. Because these types typically use demineralized water, no filter medium is required downstream. The ultrasonic humidifier is also manufactured as a freestanding unit.
- **Centrifugal humidifiers** (Figure 9C) use a high-speed disk that slings water to its rim, where it is thrown onto plates or a comb to produce a fine mist. The mist is introduced to the airstream, where it is evaporated.
- **Pressurized-water humidifiers** (Figure 9D) use a volumetric pump to generate water at pressures between 300 and 1800 psi. This high-pressure water is then transferred to a duct, air handler, or ambient space by distribution piping, and discharged through special nozzles. The nozzles use swirl jet or impaction features (Figures 9E and 9F) to produce billions of very small droplets that spontaneously evaporate, humidifying and cooling the air.

- A **duct or air handler pressurized-water system** typically consists of a pumping station, control sensor, distribution piping, a nozzle grid array with control solenoid valves, a mist eliminator section, and a limit sensor downstream of the mist eliminator.
- An **ambient pressurized-water system** typically consists of a pumping station, control sensor, distribution piping, and a manifold circuit (with or without air blowers) containing spray nozzles.
- **Compressed-air nozzle humidifiers** (Figure 9A) use a system of air and water control unit, distribution piping and nozzles. The control sections manage the flow of air and water going to the nozzles. The nozzles can operate in two ways:
 - Compressed air and water are combined inside the nozzle and discharged onto a resonator to create a fine fog at the nozzle tip (Figure 9G).
 - Compressed air is passed through an annular orifice at the nozzle tip, and water is passed through a center orifice. The air creates a slight vortex at the tip, where the water breaks up into a fine fog on contact with the high-velocity compressed air.

Wetted-Media Humidifiers. **Rigid-media humidifiers** (Figure 9H) use a porous core and the process of evaporation. Water is circulated over the media while air is blown through the openings. These humidifiers are adiabatic, cooling the air as it is humidified. Rigid-media cores are often used for the dual purpose of winter humidification and summer cooling. They depend on airflow for evaporation: the rate of evaporation varies with air temperature, humidity, and velocity.

The rigid media should be located downstream of any heating or cooling coils. For close humidity control, the element can be broken down into several (usually two to four) banks having separate water supplies. Individual pumps or solenoids controlling water flow to each bank are activated as humidification is required.

Rigid-media humidifiers have inherent filtration and scrubbing properties because of the water-washing effect in the filter-like channels. Only pure water is evaporated; therefore, contaminants collected from the air and water must be flushed from the system. A continuous bleed or regular pan flushing is recommended to minimize accumulation of contaminants in the pan and on the media. A cycles-of-concentration method can be used to minimize scale build-up and water discharge.

Hybrid Humidifiers. Hybrids (Figure 9I) combine a nozzle-type humidifier and a rigid-media humidifier. They are used in ducted or air handler applications. Nozzles, which typically operate at low pressure, are placed upstream of a rigid-media core and spray water into the airstream toward media. Droplets that do not evaporate are captured on the media and evaporated or drained off. The media functions as both a mist eliminator and an evaporator. Hybrid humidifiers normally use either RO or DI water to prevent mineral precipitation from fouling the media.

Evaporative Cooling. Atomizing and wetted media humidifiers discharge water at ambient temperature. The water absorbs heat from the surrounding air to evaporate the fog, mist, or spray at a rate of 1075 Btu per pound of water. This evaporative cooling effect (see Chapter 41) should be considered in the design of the system and if reheat is required to achieve the final air temperature. The ability of the surrounding air to efficiently absorb the fog, mist, or spray depends on its temperature, velocity, and moisture content.

Selecting Humidifiers

Each type of humidifier has its own strengths and best applications (Table 3).

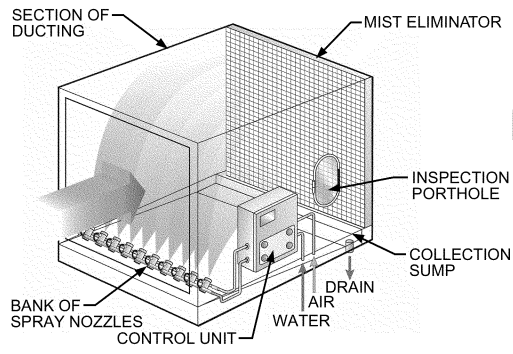

A. COMPRESSED-AIR NOZZLE HUMIDIFIER WITH MIST ELIMINATOR
(Adapted from Lazzarin et al. 2004)

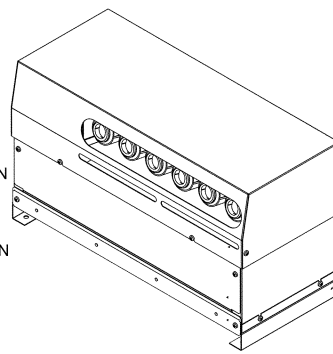

B. ULTRASONIC HUMIDIFIER
(Courtesy of STULZ Air Technology Systems, Inc.)

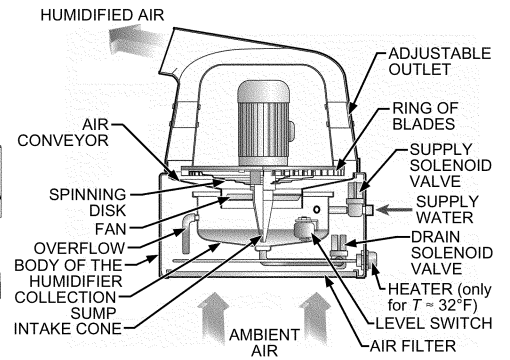

C. CENTRIFUGAL ATOMIZING STATION
(Adapted from Lazzarin et al. 2004)

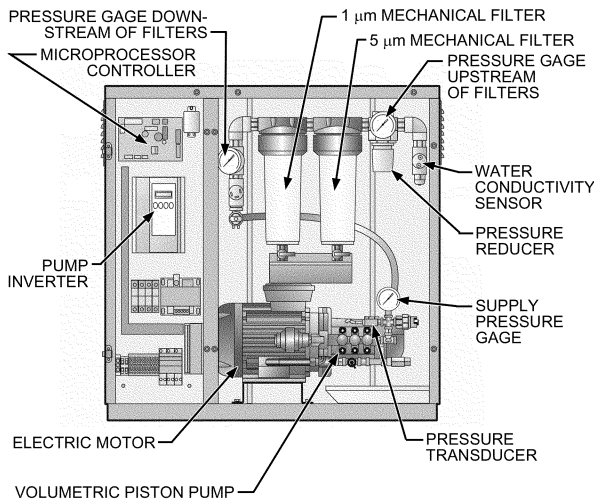

D. HIGH-PRESSURE ATOMIZING STATION
(Adapted from Lazzarin et al. 2004)

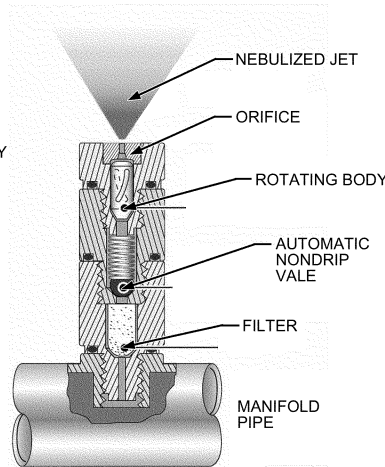

E. HIGH-PRESSURE SWIRL JET NOZZLE
(Adapted from Lazzarin et al. 2004)

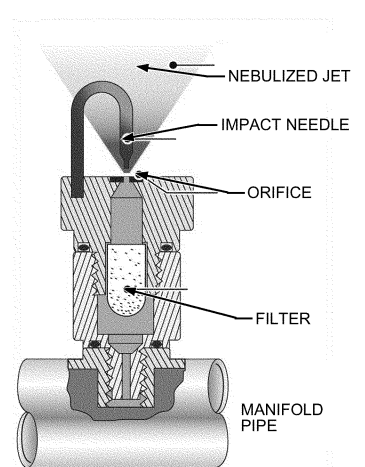

F. HIGH-PRESSURE IMPACT NOZZLE
(Adapted from Lazzarin et al. 2004)

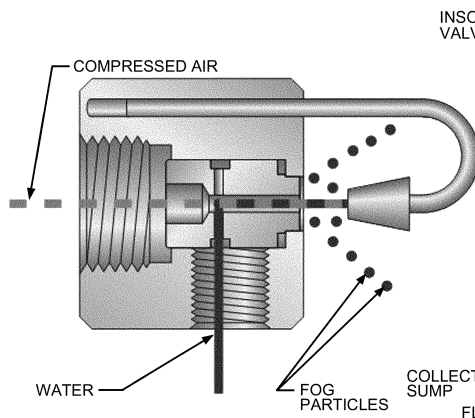

G. COMPRESSED-AIR NOZZLE
(Courtesy of Armstrong International, Inc.)

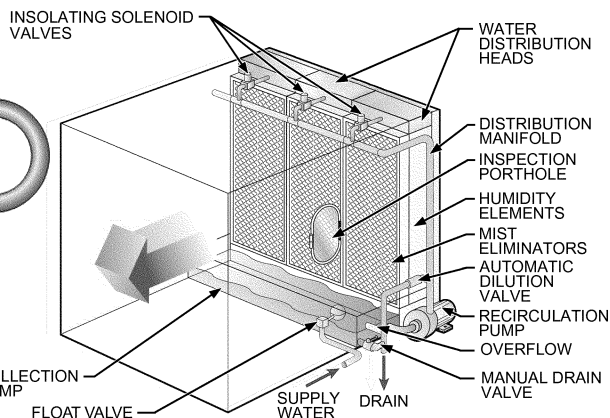

H. RIGID-MEDIA HUMIDIFIER
(Adapted from Lazzarin et al. 2004)

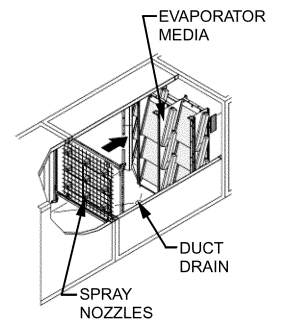

I. HYBRID HUMIDIFIER
(Courtesy of Nortec Humidity Ltd.)

Fig. 9 Industrial Adiabatic (Atomizing and Evaporative) Humidifiers

Table 3 Humidifier Advantages and Limitations

| Advantages | | Limitations | Ancillary Equipment |
|-------------------------------|--|--|--|
| <i>Adiabatic</i> | | | |
| Centrifugal | Simple Provides evaporative cooling to surrounding air | Difficult to apply to air-handling systems Limited capacity Possible plugging issues | N/A |
| Compressed air and water | Adjusts to changes in demand High turndown of output Customizable to air-handling systems Available in a wide range of capacities | Requires sufficient volume of compressed air Requires purified water Longer evaporation distances Requires sufficient preheat of air supply | Air compressor Reverse-osmosis water treatment system Three-way drain valve Mist eliminator Controls and control panel |
| High-pressure atomizers | Same benefits as compressed air and water Benefits of atomization without cost of compressed air Provides evaporative cooling to surrounding air | Requires purified water Requires sufficient preheat of air supply Longer evaporation distances | Reverse-osmosis water treatment system Mist eliminator Controls |
| Low-pressure atomizers | Benefits of atomization without cost of compressed air Potential energy benefit of evaporative cooling Lower energy consumption than high-pressure atomizers High evaporation efficiencies if used with a postevaporator Typically shorter evaporation distances than high-pressure atomizers Longer life on pumps because of lower operating pressures | Must stage discharge Requires purified water Requires sufficient preheat of air supply | Reverse-osmosis water treatment system Mist eliminator or post evaporator Controls |
| Ultrasonic | Adjusts to changes in demand, modulates output High turndown of output Customizable to air-handling systems Provides evaporative cooling to surrounding air | Uses deionized (DI) water Requires sufficient preheat of air supply Longer evaporation distances Needs to have an accurate reservoir liquid level Limited output from each piezo crystal | Deionized water treatment system Mist eliminator Controls |
| Wetted-media evaporative | Available in a wide range of capacities Provides evaporative cooling to surrounding air Low energy consumption | Slow response to reduced demand Requires biocide Nonpurified water can lead to a build-up of impurities Water collection pan must be purged periodically | Controls Recirculation pumps |
| <i>Direct-Injection Steam</i> | | | |
| Steam cup | Simple design | Limited performance features Limits in control of steam output Limitations in allowable steam capacity Unrefined sound silencing Can disperse boiler chemicals into air | N/A |
| Steam separator | Reliable performance Available in a wide range of capacities Adjusts to changes in demand Separates steam from condensate Sound silencing capability Low maintenance requirements Available with high turndown or valve rangeability Lifts condensate within stream pressure constraints Control valve can be adjusted electrically or pneumatically | Requires availability of a steam boiler Longer nonwetting distance than steam panel-type Can disperse boiler chemicals into air | Steam trap Wye-type strainer Temperature switch Controls |
| Steam panel | Reliable performance Available in a wide range of capacities Adjusts to changes in demand Separates steam from condensate Sound silencing capability Low maintenance requirements Available with high turndown or valve rangeability Short nonwetting distances Control valve can be adjusted electrically or pneumatically Performs without steam jacket or manifolds Can be insulated for energy savings | Requires availability of a steam boiler Can disperse boiler chemicals into air Difficulty lifting condensate from steam traps | Wye-type strainer Controls Condensate pump Manufacturer supplied and installed panel insulation |

5. CONTROLS

It is critical to consider how any humidification system will be properly controlled. Many aspects of the area to be humidified and how it interacts with other areas of the building must also be considered.

Water vapor concentrations equalize rapidly, moving from an area of high water vapor content to one of lower vapor content. If the space being humidified adjoins a space that does not have humidity

control, the areas must be isolated or the combined area will be humidified. Similarly, if a humidified space is connected to a ventilation system that also serves nonhumidified spaces, the water vapor will equalize throughout the total area served by the ventilation system, which could require considerably increasing the humidification system size. Also, if a space is to be controlled to a lower humidity level than adjacent spaces or the environment, infiltration of moisture from the other spaces is likely as the water vapor concentration attempts to equalize.

Table 3 Humidifier Advantages and Limitations (Continued)

| | Advantages | Limitations | Ancillary Equipment |
|-----------------------------|--|--|--|
| Heated Tank | | | |
| Electric (electrode type) | Compact size Provides a modulated output to a variable demand signal Available with cleanable or disposable tanks Available with self diagnostics Typically wall mounted | Water minerals precipitate out, remaining in tank Cannot use extremely low-conductivity water or purified water Performance can be adversely affected by long steam distribution pipe runs | Fill cup extension kits for high-back-pressure applications Optional tank drain temperature-tempering device Controls Steam dispersion tube or steam dispersion panel for shorter nonwetting distance, or steam blower to disperse steam Steam hose with clamps for steam dispersion |
| Electric (resistive type) | Can use any type of fill water: tap, softened, RO/DI Some provide modulated output through SCR/SSR control Available with self diagnostics Can be wall, floor, or rooftop mounted | Water minerals precipitate out, remaining in tank Typically larger and heavier than electrode units | Optional tank drain temperature-tempering device Controls Steam dispersion tube or steam dispersion panel for shorter nonwetting distance, or steam blower to disperse steam Steam hose with clamps for steam dispersion Roof curb for outdoor mounting |
| Infrared steam humidifiers | Simple and compact design | Infrared bulbs are sensitive and fracture Limited output capacity Control accuracy Radiant energy is converted to heat rather than evaporating water | N/A |
| Gas-fired steam humidifiers | Can use any type of fill water: tap, softened, RO/DI Low energy costs Offers models with steam capacity greater than electric units Available with self diagnostics | Water minerals precipitate out, remaining in tank unless using RO/DI water Limitations in placement because of venting requirement | Steam dispersion tube or steam dispersion panel for shorter nonwetting distance, or steam blower to disperse steam Optional tank drain temperature-tempering device Controls Sealed combustion option for dedicated combustion air Roof curb for outdoor mounting |
| Steam-to-steam | Available with self diagnostics Additive-free steam High-capacity units available Can be floor or rooftop mounted | Water minerals precipitate out, remaining in tank Condensate pump required to lift condensate discharged from steam trap | Control panel, control valve, steam trap, and strainer Steam dispersion tube, steam dispersion panel for shorter nonwetting distance, or blower for dispersing steam Roof curb for outdoor mounting Optional tank drain water-tempering device |
| Hot water humidifiers | Available with self diagnostics Additive-free steam High-capacity units available | Water minerals precipitate out, remaining in tank Minimum temperature of liquid heat source is 240°F | Controls Optional tank drain temperature-tempering device Control panel, control valve, steam trap, and strainer Steam dispersion tube, steam dispersion panel for shorter nonwetting distance, or blower for dispersing steam |

Source: Adapted from AHRI (2016).

Outdoor weather conditions can significantly affect the indoor relative humidity in a space. Cold outdoor air holds lower amounts of water vapor compared to warmer indoor air, and can lower the indoor humidity when introduced to the space. Similarly, when outdoor conditions are hot and humid, the higher water vapor content of the outdoor air will equalize with the lower water vapor in the indoor space. Therefore, proper humidity controls must be installed to manage the humidification or dehumidification system serving a controlled space.

Several different types of controls are available to serve the requirements of the project. Controls commonly provide an on/off or a modulating signal, such as 0-10 VDC or 4-20 mA, as the humidity changes from the set point. Most humidistats can be used to activate either humidification or dehumidification systems.

Mechanical Controls

Mechanical sensors depend on a change in the length or size of the sensor as a function of relative humidity. Many humidity-sensitive materials are available, such as nylon, human hair, wood, and animal membranes that change length with humidity changes. The most commonly used sensors are synthetic polymers or human hair. They can be attached to a mechanical linkage to control the mechanical, electrical, or pneumatic switching element of a valve or motor. This design is suitable for most human comfort applications, but it may lack the necessary accuracy for industrial applications.

A humidity controller is normally designed to control at a set point selected by the user. Some controllers have a setback feature

that lowers the relative humidity set point as outdoor temperature drops to reduce condensation within the structure.

Electronic Controls

Electrical sensors change electrical resistance as the humidity changes. They typically consist of two conductive materials separated by a humidity-sensitive, hygroscopic insulating material (polyvinyl acetate, polyvinyl alcohol, or a solution of certain salts). Small changes are detected as air passes over the sensing surface. Capacitive sensors use a dielectric material that changes its dielectric constant with relative humidity. The dielectric material is sandwiched between special conducting materials that allow a fast response to changes in relative humidity.

Electronic control is common in laboratory or process applications requiring precise humidity control. It is also used to vary fan speed on portable humidifiers to regulate humidity in the space more closely and to reduce noise and draft to a minimum.

Electronic controls are now widely used for residential applications because of low-cost, accurate, and stable sensors that can be used with inexpensive microprocessors. They may incorporate methods of determining outdoor temperature so that relative humidity can be automatically reset to some predetermined algorithm intended to maximize human comfort and minimize any condensation problems (Pasch et al. 1996).

Along with a main humidity controller, the system may require other sensing devices:

- **High-limit sensors** may be required to ensure that duct humidity levels remain below the saturation or dew-point level. Sometimes cooler air is required to offset sensible heat gains. In these cases, the air temperature may drop below the dew point. Operating the humidifier under these conditions causes condensation in the duct or fogging in the room. High-limit sensors may be combined with a temperature sensor in certain designs. The high-limit humidistat should be installed approximately 10 ft from the humidifier section. This distance is necessary to allow for the moisture to be fully absorbed; high limits installed closer to the humidifier risk being damaged by moisture or cycling rapidly, causing short cycling of the entire humidification system. High-limit humidistats are commonly set to a maximum of 85 to 90% rh, and should be wired to close when the relative humidity falls below the set point and open when the relative humidity exceeds the set point.
- **Airflow sensors** should be used in place of a fan interlock. They sense airflow and disable the humidifier when insufficient airflow is present in the duct. An airflow switch is typically a sail or pressure switch that opens the control circuit of the humidifier when the airflow decreases or fails, and shuts the humidifier off. During system commissioning, confirm that this switch operates properly.
- **Steam sensors** are used to keep the control valve on direct-injection humidifiers closed when steam is not present at the humidifier. A pneumatic or electric temperature-sensing switch is fitted between the separator and the steam trap to sense the temperature of the condensate and steam. When the switch senses steam temperature, it allows the control valve to function normally.

Further information on humidity sensors can be found in Chapter 36 of the 2013 *ASHRAE Handbook—Fundamentals*.

Control Location

In centrally humidified structures, the humidity controller is most commonly mounted in a controlled space. Another method is to mount the controller in the return air duct of an air-handling system to sense average relative humidity. Figure 10 shows

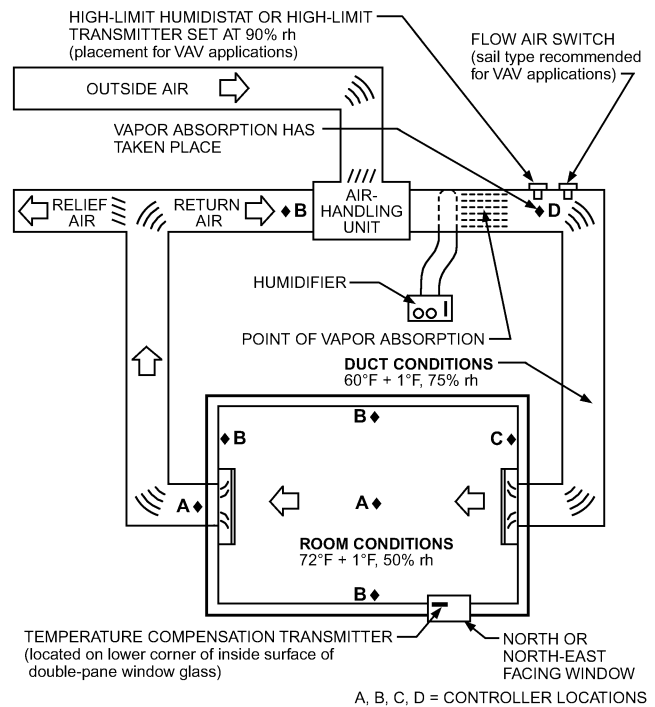

Fig. 10 Recommended Humidity Controller Location

general recommended locations for the humidistat for a centrally air-conditioned room.

The manufacturer's instructions regarding the use of the controller on counterflow furnaces should be followed because reverse airflow when the fan is off can substantially shift the humidity control point in a home. The sensor should be located where it will not be affected by (1) air that exits the bypass duct of a bypass humidifier or (2) drafts or local heat or moisture sources.

Management Systems

In many applications, humidifiers can be integrated with the building management system (BMS). These types of systems can be set up with simple analog interaction with the humidifier, or by various communication protocols.

For analog-type systems, the management system can enable/disable the unit, send proportional signals for direct humidity control, or redirect humidity sensor signals. These types of systems use various analog and digital outputs and inputs to command the humidifiers to operate, and at what level, as well as receive alarm states.

Communication protocols can be used as well to interact with and control humidification equipment. Protocols include BACnet[®], LONWORKS[®], Modbus[®], TCP/IP, SNMP, and METASYS[®]. In some cases, these protocols can fully control the humidifier, replacing the need for any analog wiring, or can monitor the status and operation of the unit, or a combination of both. Some equipment providers can also supply a user interface system that offers online access to the status and operation modes of the units. See ASHRAE *Standard 135* for more information.

6. APPLICATION CONSIDERATIONS

Humidity Control with Direct Space Humidification

Often, humidifiers are installed directly in the space they are humidifying, using humidity controllers (humidistats) for control, either installed directly within the space or mounted in the duct system of the ventilation unit serving the area. It is critical that space

humidistats be located where they can sense the actual temperature and humidity of the controlled space. Normally, this requires that they are located at the working level of the facility on an interior wall or column. Humidistats should not be installed in the following areas:

- On exterior walls
- In drafts created by the HVAC system or interior machinery
- On surfaces affected or heated by sunlight, traffic, heat from machinery, lights, or other devices
- Near skids of materials stored in hot or cold warehouses
- Near rest rooms, washing facilities, or areas where moisture or heat is produced

In these areas, local changes in temperature or moisture cause the sensed relative humidity level to differ from the space as a whole.

It is good practice to install a high-limit humidistat to protect the space from possible excessive humidity in case the controlling humidistat fails or is damaged. Normally, this high-limit humidistat is an on/off type with a set point of 5 to 10% above the desired space conditions. It is then wired to open the control circuit of the humidifier and turn the humidifier off in case the control humidistat fails to properly shut the system off.

Humidity Control with Duct-Mounted Humidification

Humidifiers are commonly installed in ductwork or an air-handling unit (AHU) to control the temperature and humidity in the space or building as a whole. For these systems, best practice is to include the following controls:

- Space humidity controller
- Duct high-limit humidity controller
- Duct air proving switch for each humidifier

The space humidity controller can either be mounted directly within the conditioned space or in the return duct leaving the conditioned space. If using the return duct method, ensure that the humidistat senses conditions representative of the space as opposed to elevated temperatures or humidity levels resulting from machinery, stratification at the ceiling, or other process in the space.

When installing humidifiers in the AHU or supply duct, consider the psychrometrics of the airstream where the humidifiers are located. Warm air can absorb more water vapor than cold air, and the temperature and volume of air flowing through the ventilation system must be able to absorb the moisture being added to the airstream without becoming saturated. If the supply air is significantly cooler than the space design, the supply air may not be able to transport the required amount of moisture to satisfy the humidification load. For example, space design conditions of 75°F and 50% rh require 0.00928 lb of moisture per pound of air. Supply air at 55°F can only hold 0.00920 lb of moisture per pound of air and will be fully saturated under these conditions. The excess moisture that cannot be absorbed will likely become deposited in the duct or AHU, where it can cause bacterial growth, odors, or corrosion.

When using steam for humidification, the characteristics of the steam distributor should be considered. Adequate distance must be allotted for the steam to fully absorb to prevent unintended condensation on coils and other surfaces in the ventilation system. It is important to keep in mind that hot steam distributor tubes often contribute a small amount of heat to the airstream, which can increase the supply air temperature.

When using adiabatic humidification, to consider the energy required to evaporate the water being discharge into the airstream. Evaporating a pound of water extracts 1075 Btu/lb from the airstream. As a result, the airstream leaving the adiabatic humidifier

will be significantly cooler than the airstream entering the humidifier. Air preheating may be required to offset this cooling effect.

Humidity Control in Variable-Air-Volume Systems

Control in variable-air-volume (VAV) systems is much more demanding than in constant-volume systems. VAV systems, common in large, central-station applications, control space temperature by varying the volume rather than the temperature of the supply air. Continual airflow variations to follow load changes in the building can create wide and rapid swings in space humidity. Because of the fast-changing nature and cooler supply air temperatures (55°F or lower) of most VAV systems, special modulating humidity controls should be applied.

Best results are obtained by using both space and duct modulating humidity sensors with an integrating device, which in turn modulates the output of the humidifier. This allows the duct sensor to respond quickly to a rapid rise in duct humidity caused when airflow to the space decreases as temperature conditions are satisfied. The duct sensor at times overrides the space humidistat by reducing the humidifier output to correspond to decreasing air volumes. This type of system, commonly referred to as **anticipating control**, allows the humidifier to track the dynamics of the system and provide uniform control. Because of the operating duct static pressures of a VAV system, using an **airflow proving device** is recommended to detect air movement.

Commissioning Systems

Each individual humidifier should have a dedicated space control, high-limit humidistat, and air proving switch. All should be calibrated and checked for accurate control capabilities when commissioning the system and periodically as recommended by the control manufacturer. Properly commissioning the humidification system according to the manufacturer's instructions is essential for long-term reliability, sustainability, performance, and ultimately owner satisfaction with the system.

REFERENCES

- AHAM. 2011. Appliance humidifiers. *Standard* HU-1-2006 (R2011). Association of Home Appliance Manufacturers, Chicago.
- AHRI. 2014. Performance rating of central system humidifiers for residential applications. ANSI/AHRI *Standard* 610-2014. Air-Conditioning, Heating, and Refrigeration Institute, Arlington, VA.
- AHRI. 2014. Performance rating of self-contained humidifiers for residential applications. ANSI/AHRI *Standard* 620-2014. Air-Conditioning, Heating, and Refrigeration Institute, Arlington, VA.
- AHRI. 2005. Commercial and industrial humidifiers. ANSI/AHRI *Standard* 640-2005. Air-Conditioning, Heating and Refrigeration Institute, Arlington, VA.
- AHRI. 2016. Common humidifiers chart. Air-Conditioning, Heating and Refrigeration Institute, Arlington, VA. ahrinet.org/App_Content/ahri/files/Contractors-Specifiers/common-humidifiers-chart2.pdf.
- ASHRAE. 2013. Thermal environmental conditions for human occupancy. ANSI/ASHRAE *Standard* 55-2013.
- ASHRAE. 2013. Ventilation for acceptable indoor air quality. ANSI/ASHRAE *Standard* 62.1-2013.
- ASHRAE. 2012. A data communication protocol for building automation and control networks. ANSI/ASHRAE *Standard* 135-2012.
- Brown, W.G., K.R. Solvason, and A.G. Wilson. 1963. Heat and moisture flow through openings by convection. *ASHRAE Journal* 5(9):49.
- Brundrett, G.W. 1990. *Criteria for moisture control*. Butterworth & Co, London.
- Harris, C.M. 1963. Absorption of sound in air in the audio-frequency range. *Journal of the Acoustical Society of America* 35(January).
- Luck, J.R., and L.W. Nelson. 1977. The variation of infiltration rate with relative humidity in a frame building. *ASHRAE Transactions* 83(1): 718-729.

- Pasch, R.M., M. Comins, and J.S. Hobbins. 1996. Field experiences in residential humidification control with temperature-compensated automatic humidistats. *ASHRAE Transactions* 102(2):628-632.
- Puckorius, P.R., P.T. Thomas, and R.L. Augspurger. 1995. Why evaporative coolers have not caused Legionnaires' disease. *ASHRAE Journal* 37(1): 29-33.
- Ruud, C.O., J.W. Davis, and R.F. Unz. 1993. Analysis of furnace-mount humidifier for microbiological and particle emissions—Part II: Particle sampling and results. *ASHRAE Transactions* 99(1):1387-1395.
- Sterling, E.M., A. Arundel, and T.D. Sterling. 1985. Criteria for human exposure to humidity in occupied buildings. *ASHRAE Transactions* 91(1B):611-622.
- Unz, R.F., J.W. Davis, and C.O. Ruud. 1993. Analysis of furnace-mount humidifiers for microbiological and particle emissions—Part III: Microbiological sampling and results. *ASHRAE Transactions* 99(1):1396-1404.
- Wilson, A.G., and W.P. Brown. 1964. Thermal characteristics of double windows. *Canadian Building Digest* 58. Division of Building Research, National Research Council, Ottawa, ON.
- Davis, J.W., C.O. Ruud, and R.F. Unz. 1993. Analysis of furnace-mount humidifier for microbiological and particle emissions—Part I: Test system development. *ASHRAE Transactions* 99(1):1377-1386.
- Harriman, L., G. Brundrett, and R. Kittler. 2008. *Humidity control design guide for commercial and institutional buildings*. ASHRAE.
- Lazzarin, L., and L. Nalini. 2004. *Air humidification—Technical, health and energy aspects*. CAREL Industries, Brugine, Italy.
- Noti, J.D., F.M. Blachere, C.M. McMillen, W.G. Lindsley, M.L. Kashon, D.R. Slaughter, and D.H. Beezhold. 2013. High humidity leads to loss of infectious influenza virus from simulated coughs. *PLoS ONE* 8(2): e57485. journals.plos.org/plosone/article?id=10.1371%2Fjournal.pone.0057485.
- Rief, S., and M. Jurecic. 2014. Air humidity in the office workplace—Study on the significance of air humidity in the office. Joint research project Office 21®. Fraunhofer Institute for Industrial Engineering, Stuttgart. Available at shop.iao.fraunhofer.de/details.php?id=633.
- Wyon, D.P., L. Fang, L. Lagercrantz, and P.O. Fanger. 2006. Experimental determination of the limiting criteria for human exposure to low winter humidity indoors (RP-1160). *HVAC&R Research* (now *Science and Technology for the Built Environment*) 12(2):201-213.

BIBLIOGRAPHY

Berglund, L.G. 1998. Comfort and humidity. *ASHRAE Journal* 40(8): 35-41.